

MATERIAL: SEE B/M
 DRAWN: TFK CHECKED: DEP
 SCALE: NONE DATE: 06/12/97



SIGHT WINDOW
 5200 PVQ-ASME VIII SERIES

Section: T400
 Bulletin: T400.56
 Date: 12/01/00
 Supersedes: 11/10/98

150, 300, 600 PSIG MODELS

FILE NO.: T400-56.DWG

CONSTANT DIMENSIONS					150 LB.		300 LB.		600 LB.	
SIZE	A(IN)	A(mm)	B(IN)	B(mm)	C(IN)	C(mm)	C(IN)	C(mm)	C(IN)	C(mm)
#2	3.88	99	1.25	32	2.31	32	2.44	62	2.44	62
#3	5.00	127	2.00	64	2.50	64	2.63	67	2.63	67
#4	6.50	165	2.56	65	3.28	83	3.40	86	3.40	86
#5	7.50	191	3.19	81	3.28	83	3.65	93	3.40	86
#6	8.25	210	4.19	107	3.16	80	3.40	86	3.91	99
#7	9.38	238	5.25	133	3.72	94	4.22	107	4.47	113
#8	11.00	279	6.75	171	3.97	101	4.97	126	5.47	138
#10	14.00	355	8.00	203	4.22	107	5.22	132	5.72	145
#12	16.75	425	11.00	279	5.28	134	5.91	150	TBD	TBD

PARTS LIST				
PIECE NO.	NAME OF PART	QUAN.	MATERIAL	COMMENTS
1	BODY	1	SEE BELOW	
2	GASKET	1		
3	RETAINER	1	STEEL	
4	WINDOW	1	BOROSILICATE	
5	STUD		STEEL	
6	NUT		STEEL	
7	CUSHION	1	FIBER	

THIS DRAWING AND ALL INFORMATION ON IT IS THE PROPERTY OF JACOBY-TARBOX, DIVISION OF THE CLARK-RELIANCE CORPORATION. IT IS CONFIDENTIAL AND IS GIVEN TO YOU FOR A LIMITED PURPOSE AND MUST BE RETURNED UPON REQUEST. NEITHER THIS DRAWING NOR ANY PART OF IT NOR ANY INFORMATION CONCERNING IT MAY BE COPIED, EXHIBITED OR FURNISHED TO OTHERS NOR MAY PHOTOGRAPHS BE TAKEN OF ANY ARTICLE FABRICATED OR ASSEMBLED FROM THIS DRAWING WITHOUT CONSENT OF THE CLARK-RELIANCE CORPORATION.



Approved

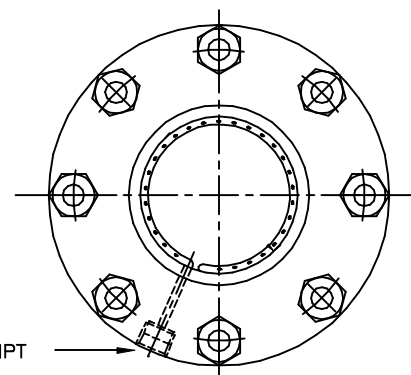

RETAINER PATTERN SHOWN WITH OPTIONAL SS SPRAY RING

TEMP F	ALL MATERIALS (PSI)		
	150#	300#	600#
-20 TO 100	150	300	600
150	150	300	600
200	150	300	600
250	150	300	600
300	150	300	600
350	150	300	600
400	150	300	600
450	150	300	600
500	150	300	600

# OF STUDS	
SIZE	STUDS
#2	4
#3	4
#4	8
#5	8
#6	8
#7	8
#8	8
#10	8
#12	12

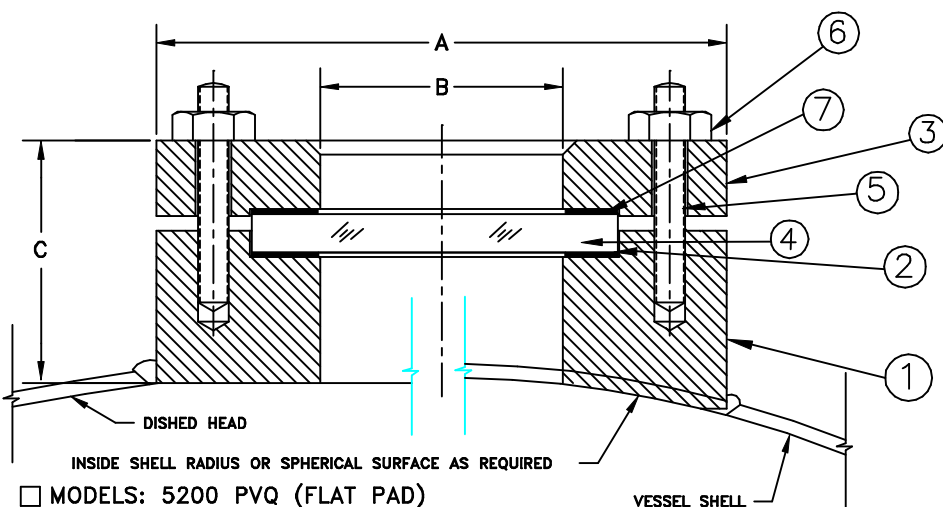
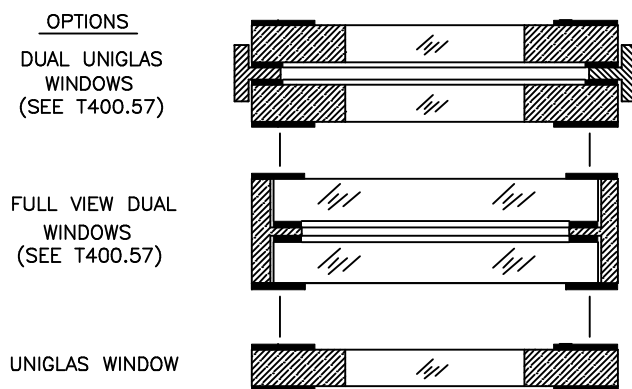

- MODELS: 5200 PVQ (FLAT PAD)
- MODELS: 5200 PVQ-CYL (PIPE RADIUS)
- MODELS: 5200 PVQ-SPH (DISHED SPHERICAL)

STANDARD DESIGN MATERIALS:
 BODY: ASTM/ASME SECTION II SA516-70/SA216-WCB/SA106 (STEEL)
 ASTM/ASME SECTION II SA240/SA351-CF8/CF8M (304/316 SS)
 RETAINER: ASTM/ASME SECTION II SA516-70/SA216-WCB/SA106 (STEEL)
 FASTENERS: ASTM A193-B7/A194-2H
 304/316 SS TRIM AVAILABLE
 OPTIONAL ALLOYS FURNISHED UPON REQUEST
 MIN. PAD THICKNESS "C" IS CALCULATED PER UG-44 FOR BOLTED FLANGE AND STUDDED CONNECTIONS. THE CLIENT IS RESPONSIBLE FOR VERIFICATION THAT THE WELD PAD THICKNESS WILL MEET THE PERFORMANCE REQUIREMENTS OF THE APPLICATION