

INSTALLATION/OPERATION/MAINTENANCE INSTRUCTIONS FOR □  
MODELS WD2010L, WD2010, WD2010H WASHDOWN STATIONS

# Washdown Stations

Models **WD2010L, WD2010, WD2010H**

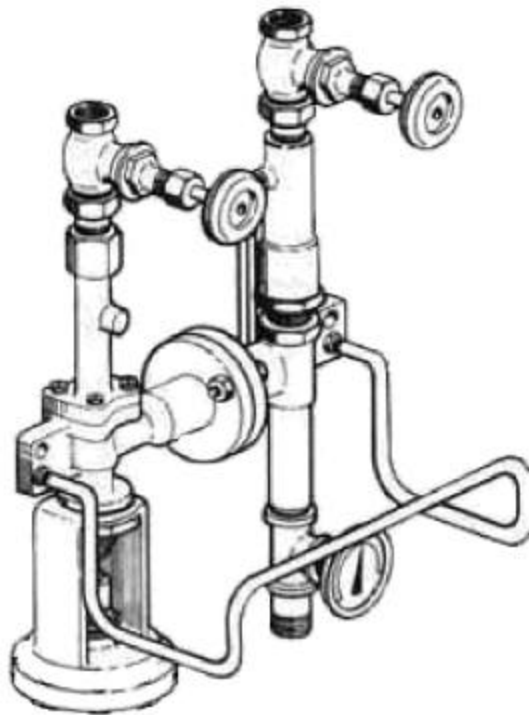

## Installation / Operation / Maintenance Instructions

Northeast Controls Inc. □  
Upper Saddle River, New Jersey 07458 USA □  
Tel: 201-327-7660 | Fax: 201-327-3242 | [sales@washdownstations.com](mailto:sales@washdownstations.com) □  
<http://www.washdownstations.com> □

# INSTALLATION/OPERATION/MAINTENANCE INSTRUCTIONS FOR □ MODELS WD2010L, WD2010, WD2010H WASHDOWN STATIONS

This manual has been prepared as an aid and guide for personnel involved in installation or maintenance. All instructions must be read and understood thoroughly before attempting any installation, operation, or maintenance. Failure to follow any instruction can possibly result in a malfunction of the washdown station resulting in physical injury to personnel. Additionally, property damage can occur.

**Important:** NCI does not have control over the manner in which its washdown station is handled, installed, or used, and NCI cannot and does not warrant or guarantee that a washdown station is suitable or compatible with the user's specific application.



**Always wear safety glasses, face shield, wet suit, boots and gloves, when installing, servicing or operating a washdown station.**

## I. INTRODUCTION:

### A. Features and Specification

The NCI washdown station is a complete, pre-engineered package including:

1. Manually operated valves for steam and water supply lines.
2. Diaphragm operated steam valve that opens when 5 to 6 GPM (3 to 4 GPM for the WD2010L) of water is flowing.
3. Flow sensing element, an orifice that senses the full flow of water to be heated.
4. Integral steam and water line check valves to prevent back flow.
5. Positive steam safety shut-off.
6. Discharge liquid temperature gage.
7. Integral direct steam injection heater.
8. Swivel hose fitting at discharge connection.
9. Integral wall mounting system.
10. Integral stainless steel hose rack.
11. Available with 25 or 50 Ft. of hose w/trigger-operated spray gun or the automatic shut-off lance.

NCI washdown stations are designed to heat the water by direct contact with steam, producing an efficient means of cleanup for most industrial plants where cleaning applications are required.

### B. Design Rating PSIG at Maximum and Minimum Operating Temperatures

To determine the maximum allowable working pressure for a specific temperature, the user must refer to Archon dimension sheets, or when provided, the specifically stated design limits on an Archon product proposal.

### C. Application Data: Recommended Operating Ranges

Model	Saturated Steam Pressure (psig)	Water Pressure (psig)	Discharge flow range
WD2010L	10-60	30-80	3 to 4.5 GPM
WD2010	35-150	30-80	3 to 8.5 GPM
WD2010H	60-200	30-80	3 to 9 GPM

For optimum performance, it is recommended that the water be supplied at a pressure of 5 to 10 psi lower than the pressure at which steam is supplied.

Maximum water discharge temperature should be limited to 190F.

# INSTALLATION/OPERATION/MAINTENANCE INSTRUCTIONS FOR □ MODELS WD2010L, WD2010, WD2010H WASHDOWN STATIONS

**Note:** For specific application data within the above ranges, consult the NCI product proposal or request NCI to supply the applicable Technical Data Bulletin.



**DANGER:** Never exceed these design ratings or application data limits. Exceeding these limits can cause serious personal injury and/or property damage.



**DANGER:** NCI WD2010 washdown stations are designed as systems. Operation without hose and approved nozzle to provide back pressure can result in personal injury to personnel and damage to property. Consult the factory for optional installation instructions.

## II. INSPECTION AND PERFORMANCE CONFIRMATION:

### A. Receiving Inspection

Upon receipt of washdown station, check all components carefully for damage incurred in shipping. If damage is evident or suspected, do not attempt installation. Notify carrier immediately and request damage inspection.

### B. User's Rating Inspection

The user is to confirm that:

1. The washdown station conforms to the description on the user's purchase order.
2. The operating conditions described in the purchase order agree with the actual conditions at the installation site.
3. The actual operating conditions at the installation site are within the application data shown on the Archon Technical Data Bulletin or product proposal referred to above.
4. The materials of construction of the washdown station are compatible with the contained fluid and surrounding atmosphere in the specific application.

**Important:** If the performance data of the washdown station as received, does not conform with any of the criteria above, do not proceed with installation. Contact NCI for direction on what to do.

## III. INSTALLATION:

Use only qualified experienced personnel who are familiar with this equipment and thoroughly understand all the instructions in this manual for the installation of this equipment.

# INSTALLATION/OPERATION/MAINTENANCE INSTRUCTIONS FOR □ MODELS WD2010L, WD2010, WD2010H WASHDOWN STATIONS

Refer to NCI dimension sheets or NCI product proposal to obtain dimensional information for the specific washdown station. Check Figure 1 for the location of the liquid supply, steam inlet, and liquid outlet connections to insure correct hookup.

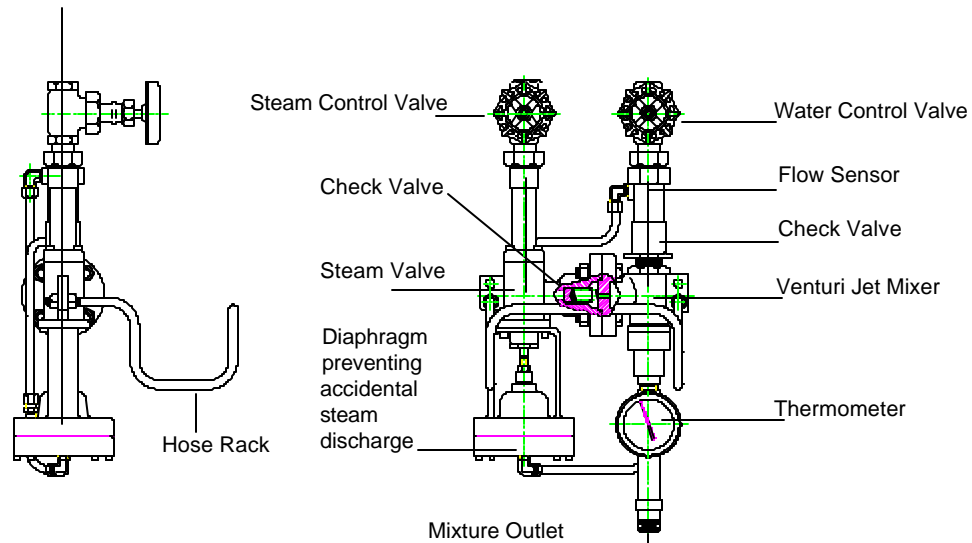

Figure 1

## A. Mounting

1. Although the washdown station can be oriented in any position, it is recommended to position the unit with the steam and water inlet lines vertically. In this manner, the thermometer dial will be up-right, and the discharge line will be pointing down.
2. Prior to mounting unit, remove the manually operated valves by loosening the union connection on the bottom of each valve. Mount valves to inlet piping using Teflon tape or equivalent on all male pipe threads as shown in Figure 3.
3. Mount the washdown station to the wall by drilling two (2) 5/8" diameter holes, minimum 1-1/2" deep, with masonry drill 9 1/16" apart and on a horizontal plane. See Figure 2. After drilling holes, insert bolt anchors into holes until they are flush with the wall.
4. Insert 3/8" diameter bolts through the holes in the mounting lugs and thread bolts into anchors making sure that the pipe spacers are in place. See exploded view for proper sequence.
5. After mounting to wall, wrench-tighten union connections of each manually operated valve.

Northeast Controls Inc. □  
Upper Saddle River, New Jersey 07458 USA □  
Tel: 201-327-7660 | Fax: 201-327-3242 | sales@washdownstations.com □  
<http://www.washdownstations.com> □

# INSTALLATION/OPERATION/MAINTENANCE INSTRUCTIONS FOR □ MODELS WD2010L, WD2010, WD2010H WASHDOWN STATIONS

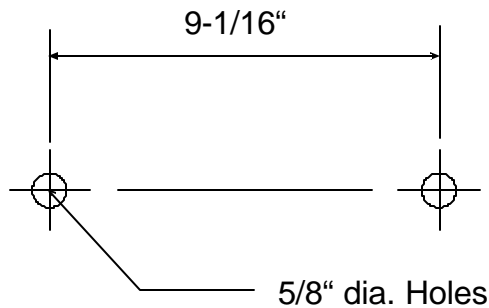

Figure 2

## B. Effect of Related Piping and Precautions

1. The washdown station should be installed with piping and fittings that provide minimum resistance to flow. Pipeline friction losses must always be a consideration when estimating washdown station performance.
2. It is recommended that provisions be made for pressure gage connections near the water inlet, and steam inlet connections of the washdown station. If performance problems occur during operation, it may be necessary to install pressure gages to identify the problem.
3. Steam must not have over 20F of superheat, or performance will differ from that published on NCI Technical Data Bulletin or product proposal referred to above.
4. Steam line must be clean, insulated, and as short as possible to prevent condensation of steam and excessive line friction losses.
5. Do not impose system -piping loads on washdown station. Unit is designed to be supported by the wall-mounting bracket.
6. It is recommended that the steam line be provided with a steam trap and strainer. It is also recommended to install an in-line water strainer in the water supply line to prevent occlusion of the line.

## IV. OPERATION

### A. Pre-operational Check

1. Check that all installation instructions have been completed.
2. Check that the manually operated steam valve is fully closed.
3. Check that the manually operated water valve is fully closed.

### B. Operating

1. Turn water valve fully on. Keep it on throughout the entire operation process.
2. Depress trigger of spray gun to establish full flow of water.
3. Slowly and partially open the manually operated steam line valve to first check for leaks. If leaks are evident, close valve, allow line to cool off, tighten connections, and repeat procedure until all leaks are stopped.
4. Slowly open the manually operated steam valve (no more than 1/2 turn) while depressing the trigger of the spray gun, then adjust the steam valve slowly until the desired water outlet temperature is obtained.

**Important: When adjusting outlet temperature of the washdown station, make certain the discharge spray gun is pointing in a safe direction.**

### C. Shutdown

## INSTALLATION/OPERATION/MAINTENANCE INSTRUCTIONS FOR □ MODELS WD2010L, WD2010, WD2010H WASHDOWN STATIONS

1. While squeezing the trigger of the spray gun, turn the manually operated steam line valve off in order to remove the steam line pressure and allow the unit to cool as much as possible before shutdown.
2. Release the trigger of the spray gun and turn the manually operated water valve fully off.



**DANGER: Do not proceed with any maintenance unless the washdown station has been relieved of all pressure, has been allowed to reach ambient temperature, and has been drained or purged of all fluids. Failure to do so can cause serious personal injury to personnel.**

### V. MAINTENANCE

Use only qualified experienced personnel who are familiar with this equipment and thoroughly understand all the instructions in this manual for all maintenance.

#### A. Preventive Maintenance

Create maintenance schedules, safety manuals and inspection details for each washdown station.

On all installations, regularly check the following items for purposes of maintenance.

1. Washdown station components, for corrosion and to remove debris build-up.
2. Piping and fittings, for corrosion and to remove debris build-up.
3. All connections, to maintain tightness and eliminate leaks.
4. Outlet temperature, to maintain desired setting.
5. Steam line strainer, to remove debris build-up.
6. Hose and spray gun, for damage or wear.
7. Stream trap, for proper operation.
8. Mounting connections, for tightness.

By evaluating your own operating experience, develop an appropriate maintenance schedule necessary for the specific application. Realistic maintenance schedules can only be determined with full knowledge of the services and application situation involved.

#### B. Maintenance Procedure

1. Leaks at threaded connection should be corrected by taking the washdown station out of service and remaking the connection using Teflon tape or equivalent on all male pipe threads as shown in Figure 3.

Northeast Controls Inc. □  
Upper Saddle River, New Jersey 07458 USA □  
Tel: 201-327-7660 | Fax: 201-327-3242 | sales@washdownstations.com □  
<http://www.washdownstations.com> □

INSTALLATION/OPERATION/MAINTENANCE INSTRUCTIONS FOR □  
MODELS WD2010L, WD2010, WD2010H WASHDOWN STATIONS

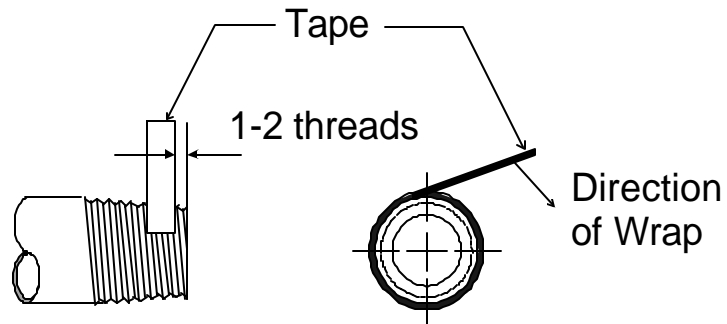

Figure 3

2. A washdown station, which leaks at an O-Ring or gasket, should be immediately corrected by tightening the bolts at the connection or by taking the washdown station out of service and replacing the O-Ring or gasket.
3. Leaks at the diaphragm should be corrected by tightening the bolts at the diaphragm cap (8), or by taking the unit out of service and replacing the diaphragm.
4. The stem packing in this unit is spring washer loaded and should seldom require adjusting, however, if a stem packing leak does occur it can be stopped by tightening the stem packing gland (1/8 turn clockwise, at a time) until the leak stops. If the leak persists, the stem packing should be replaced.

Signs of an internal steam valve stem leak, or check valve leak, is an indication of a worn or damaged stem or seat. Replace the stem; if this does not alleviate the problem, contact NCI.

Northeast Controls Inc. □  
Upper Saddle River, New Jersey 07458 USA □  
Tel: 201-327-7660 | Fax: 201-327-3242 | sales@washdownstations.com □  
<http://www.washdownstations.com> □

INSTALLATION/OPERATION/MAINTENANCE INSTRUCTIONS FOR □  
MODELS WD2010L, WD2010, WD2010H WASHDOWN STATIONS

**C. Troubleshooting**

**Problem: Diaphragm operated steam valve fails to open.**

<b>Cause</b>	<b>Cure</b>
Less than 5 to 6 GPM water flow.	Make sure manually operated steam valve is turned off and raise water pressure to achieve a minimum of 5 to 6 GPM (3 to 4 GPM for the WD2010L) water flow.
Blockage of water flow path through unit	Remove discharge hose and open water valve to check water flow through unit.
Blockage of water flow path outside unit.	Remove union valve connections to unit and open water valve to check water flow.
Damaged diaphragm.	Follow Disassembly-Reassembly steps Section V., Paragraph D. below and check for damage to diaphragm and replace it if necessary.

**Problem: Outlet water temperature is slow in responding to desired temperature.**

<b>Cause</b>	<b>Cure</b>
Condensate in steam line.	Install or correct operation of steam trap in steam line near unit.

**Problem: Outlet water temperature is less than desired.**

<b>Cause</b>	<b>Cure</b>
Operating conditions do not meet requirements to properly operate unit.	Check application, including consulting with NCI to determine operating conditions.
Water supply pressure too low with respect to steam supply pressure.	Install water line pressure regulator to reduce water supply pressure to 5 to 10 psi less than the steam supply pressure.

**Problem: The heated water spray leaving the spray gun shows bursts of steam (water vapor).**

<b>Cause</b>	<b>Cure</b>
Steam flow too high. Operating above the recommended 190F outlet water temperature limit.	Throttle the steam flows or increase water flow to reduce the discharge water temperature

Northeast Controls Inc. □  
Upper Saddle River, New Jersey 07458 USA □  
Tel: 201-327-7660 | Fax: 201-327-3242 | sales@washdownstations.com □  
<http://www.washdownstations.com> □



# INSTALLATION/OPERATION/MAINTENANCE INSTRUCTIONS FOR □ MODELS WD2010L, WD2010, WD2010H WASHDOWN STATIONS

## D. Removal-Disassembly-Reassemble



**Danger: Do not proceed with removal of washdown station unless the washdown station has been relieved of all pressure, has been allowed to reach ambient temperature, and has been drained or purged of all fluids. Failure to do so can cause serious personal injury to personnel.**

### 1. Preparation

Secure a workbench sufficiently sized to lay out parts as they are removed, and which is equipped with a vise.

**Refer to figure 5 for Washdown Station parts identification. Item numbers shown in Figure 5 are listed in parentheses below.**

### 2. Removal of unit from mounting location.

- Remove hose and spray gun assembly from discharge connection of washdown station and set aside.
- Loosen union coupling nuts of manually operated steam and water valves (75S, 75W).
- While holding unit firmly to keep it from falling, loosen and remove anchor bolts (245) to wall.
- Remove unit from wall along with pipe spacers (79) and set aside.

### 3. Disassembly

#### 3.1 Water Section

- Loosen and remove nuts (4A) holding hose rack (246) to mounting lugs and remove hose rack.
- Loosen tubing connections and remove both tubing (171) from unit.
- Loosen orifice retaining nut (4) away from orifice fitting (244) and unscrew orifice from nozzle (61). Exercise caution when unscrewing orifice, as the spring retainer (116), spring (140), and orifice check valve (75A) will become free.
- Remove spring retainer, spring, and orifice check valve from orifice fitting.
- Remove nozzle (61).
- Remove O-Ring (39) from nozzle.
- Loosen and remove 2 bolts (100) at the steam flange connection. Remove jet (82) and the flange O-Ring (39A).

#### 3.2 Steam Section

- Remove spring (140A) and steam check valve (75B) from steam valve body (11).
- Loosen and remove the 4 cap screws (100B) holding the steam extension (74) in place. Remove the extension and O-ring (39B).
- Loosen stem locking nut (4C) at connector (103) as far as it will go.
- Hold the upper diaphragm casing (45) in a vise. Scribe a common line on both the lower diaphragm casing and the lower diaphragm casing (90) to facilitate orientation during re-assembly.
- Loosen and remove the 8 cap screws (100C) to remove the lower diaphragm casing. Note: If the lower casing does not part from the diaphragm and upper casing freely, strike the side of the lower casing gently with a rubber covered mallet to loosen from the upper casing.
- While applying hand pressure to the top of the diaphragm retainer (217), remove the retainer, diaphragm (182), and piston (116A) from the connector by removing the cap screw (100D).
- Disassemble upper diaphragm casing from the valve body (11) by removing the 2 cap screws (100D).
- Unthread connector (103) from end of stem (17) by turning in a counter-clockwise direction.
- Turn packing gland (19) counter-clockwise to loosen from the valve body (11) bonnet.
- Remove stem locking nut (4C) and push stem out through body.
- Remove packing gland (19), washers (125A), wavewashers (125), stem packing (25), and O-ring (39D) from body (11).

# INSTALLATION/OPERATION/MAINTENANCE INSTRUCTIONS FOR □ MODELS WD2010L, WD2010, WD2010H WASHDOWN STATIONS

Discard all O-Rings and the valve packing (Teflon). **Do not reuse these parts under any circumstances.**



**DANGER: O-Rings and gaskets are permanently deformed by compression and if reused can cause leaks resulting in the release of live steam. This can cause serious personal injury and/or property damage.**

## 4 Reassemble

### 4.1 Water Section

- a. Set orifice body (244) on table, inlet end down.
- b. Insert check valve (75A) into orifice body making sure it slides into the locating guides in the body.
- c. Place spring (140) into open end of check valve.
- d. Thread the nut (4) onto the nozzle (61). The nut should be threaded onto the nozzle until it bottoms out on the nozzle hex.
- e. Assemble O-ring (39) into groove in the nozzle. Lubricate the O-ring before assembly.
- f. Thread the nozzle into the orifice body (which is vertical on the table) with retainer bar (116) in place, until there is approximately a 3/8" gap between the nut on the nozzle and the end of the orifice body.
- g. Turn the nut down against the orifice body hand tight.
- h. Turn the orifice body over and check for check valve (75A) movement using a 1/8" diameter rod. Push the check valve down. The valve should travel freely, min. 1/4", and should spring back freely when the rod is pulled out rapidly. This is the check valve, it must move freely.
- i. Assemble nozzle (61) into jet (82). The nozzle should be threaded into the jet as far as it will go and tightened.
- j. Loosen nut on orifice body. Turn the orifice body until the lower pressure tap on the orifice body is oriented to the same side as the jet flange. See the assembly drawing for pictorial detail.
- k. Tighten nut against the orifice body.

### 4.2 Steam Section

- a. Holding the steam valve body (11) upside down (note nameplate orientation), insert the threaded end of the stem (17) into the threaded end of the body until the stem bottoms out on the seat. Assemble washers (125A), wavewashers (125), stem packing (25), O-ring (39D) and stem packing gland (19) over the stem. See Figure 4.  
Care should be taken when assembling the stem packing over the stem threads so as to not damage the packing. Turn packing gland (19) clockwise so the underside of the hex contacts the valve body (11) bonnet.  
**Note: Discard and replace any packing that does not freely slide down into the valve packing chamber.** This is caused by flat spots on the outside of the packing.
- b. Assemble nut (4C) onto stem. Thread nut all the way down on the stem.
- c. Assemble O-ring (39E) in groove of connector (103).
- d. Place valve body in a vise with valve seat facing down. Thread connector (103) onto end of stem (17) by turning in a clockwise direction.
- e. Install upper diaphragm casing (45) over the extension (103) and onto the valve body (11). Secure the upper diaphragm casing to the valve body using the 2 cap screws (100D).
- f. Assemble the spring (140D), piston (217), diaphragm (182), and retainer (116A) to the bottom end of the connector using cap screw (100D). Ensure that the piston is installed so that the flared edge of the piston faces towards the valve stem. Ensure that the piston is secured flush to the connector and that the stem is fully seated in the body (valve closed).
- g. Thread the assembly of the connector, piston, diaphragm, and retainer on the stem until the flared edge of the piston bottoms on the inside of the upper diaphragm casing.

## INSTALLATION/OPERATION/MAINTENANCE INSTRUCTIONS FOR □ MODELS WD2010L, WD2010, WD2010H WASHDOWN STATIONS

- h. With the valve stem fully against the seat, and the piston flared edge bottomed against the inside of the casing, turn the connector in counter-clockwise direction five-5 complete revolutions. Tighten nut on stem against the connector to hold in place. (This sets the stroke of the valve from full closed to full open)
- i. Align holes in lower diaphragm casing, with holes in diaphragm.
- j. Assemble upper diaphragm casing to the lower diaphragm casing using the eight-8 cap screws (100C). Re-align upper and lower diaphragm casings at the previously scribed line. Cap screws should be torqued to 3-4 ft./lbs.
- k. Rotate the assembly in the vice so that the upper diaphragm casing (45) is upright. Place O-ring (39E) over end of extension (103) and connect extension to valve body using four-4 cap screws (100B). Cap screws should be torqued to 7-8 ft./lbs.
- l. Install tubing (171) to valve body connections hand-tight only.
- m. Install steam check valve (75B) and spring (140A) in the valve body. Install O-ring (39A) on the jet body (82). Ensuring that the two sides line up laterally, loosely assemble steam valve body (11) to the jet body (82) with two bolts and nuts (100), (4B). Do not tighten bolts.
- n. Attach tubing (171) to jet body and tighten connections.
- o. Tighten two-2 bolts (100) at valve to jet connection.
- p. Assemble hose rack (246) and place in lower holes in the mounting lugs. Secure in place with nuts (4A).

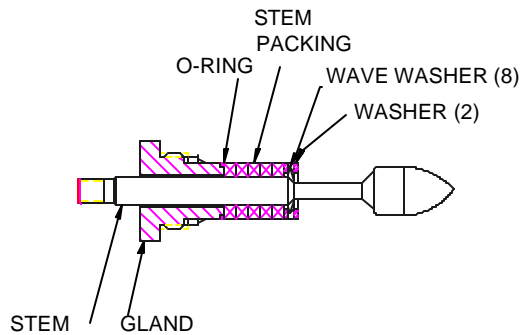

Figure 4

### 5. Re-Mounting

- a. Re-mount the assembled unit with pipe spacers (79) and bolts (100A).
- b. Tighten union coupling nuts (99) of manually operated steam and water valves (75S) (75W).
- c. Reconnect discharge hose and spray gun assembly to unit.  
Refer to Section III Installation and Section IV Operation when returning washdown station to service.

Northeast Controls Inc. □  
Upper Saddle River, New Jersey 07458 USA □  
Tel: 201-327-7660 | Fax: 201-327-3242 | sales@washdownstations.com □  
<http://www.washdownstations.com> □

INSTALLATION/OPERATION/MAINTENANCE INSTRUCTIONS FOR □  
MODELS WD2010L, WD2010, WD2010H WASHDOWN STATIONS

REF.NO	DESCRIPTION	REF.NO	DESCRIPTION
4	Nut, Nozzle	98	Tee
4A	Nut, Rack 7/16"	98	Tailpipe
4B	Nut, Flange 1/2"	99A	Nut, Tailpipe
4C	Nut, Stem 5/16'	100	Screw, 1/2"
11	Body	100A	Screw, 3/8"
17	Stem	100B	Screw, 1/4"
19	Gland, Packing	100C	Screw, #8
25	Packing, Teflon Ring Set	100D	Screw, 1/4"
39	O-Ring, Body/ Nozzle	103	Connector
39A	O-Ring, Flange	116	Check Valve Retainer
39B	O-Ring, Extension	116A	Diaphragm Retainer
39D	O-Ring, Packing	125	Wave Washer
39E	O-Ring, Connector	125A	Washer
39V	O-Ring, Nozzle / Jet	140	Water Check Spring
45	Casing, Upper Diaphragm	140A	Steam Check Spring
61	Nozzle	140D	Diaphragm Spring
74	Extension	148	Bushing
75W	Valve, Water Shut-off	171	Tube, Z
75S	Valve, Steam Shut-off	172	Tube, L
75A	Valve, Check	182	Diaphragm
75B	Valve, Check	206	Fitting, Straight
79	Spacer Nipple	207	Fitting, Elbow
82	Jet	217	Diaphragm Piston
90	Casing, Lower Diaphragm	244	Orifice Body
91	Thermometer	245	Anchor
		246	Rack

Northeast Controls Inc. □  
Upper Saddle River, New Jersey 07458 USA □  
Tel: 201-327-7660 | Fax: 201-327-3242 | sales@washdownstations.com □  
<http://www.washdownstations.com> □

INSTALLATION/OPERATION/MAINTENANCE INSTRUCTIONS FOR □  
 MODELS WD2010L, WD2010, WD2010H WASHDOWN STATIONS

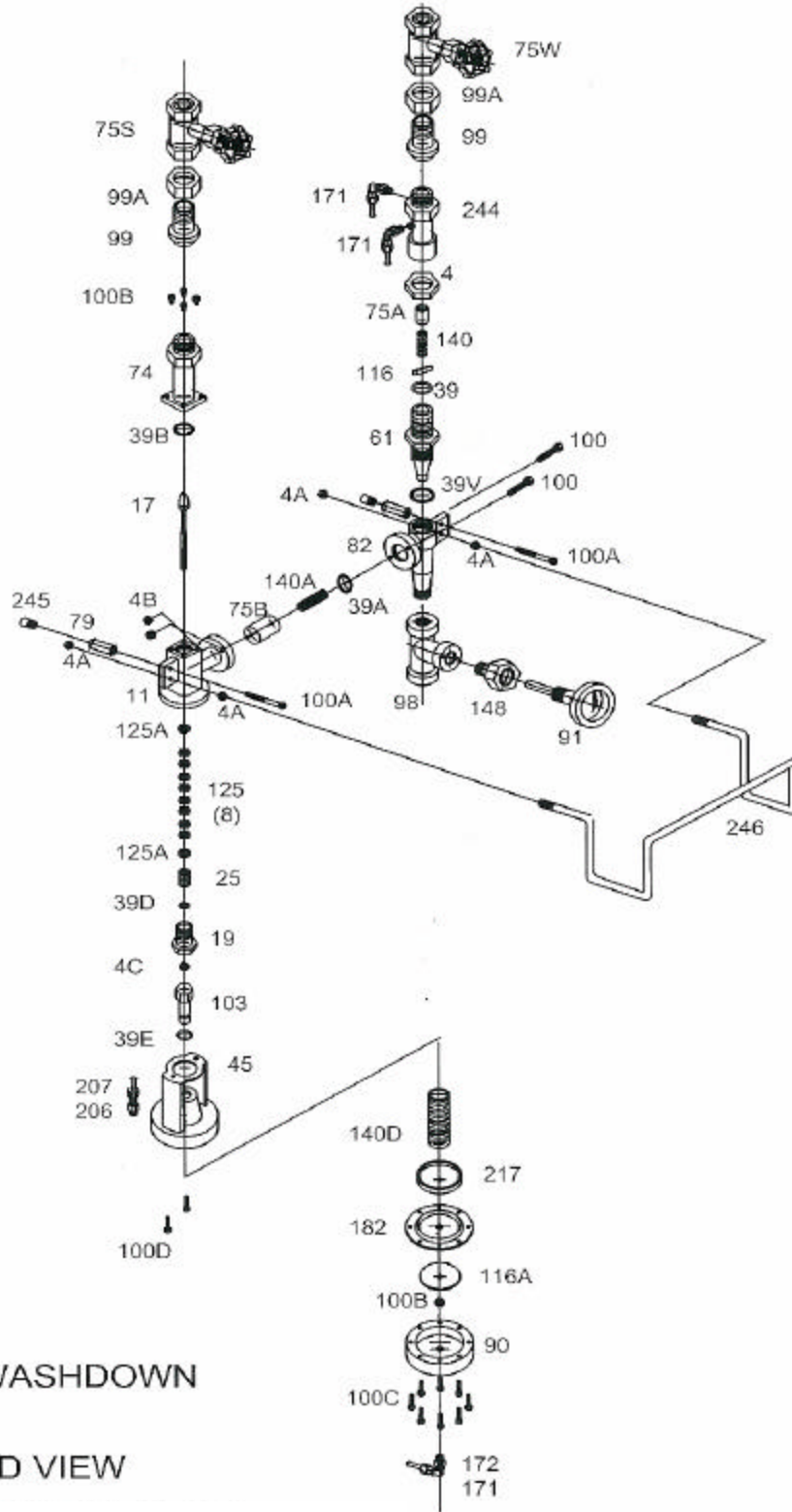

WD2010 WASHDOWN  
 STATION  
 EXPLODED VIEW

Northeast Controls Inc. □

Upper Saddle River, New Jersey 07458 USA □

Tel: 201-327-7660 | Fax: 201-327-3242 | sales@washdownstations.com □

http://www.washdownstations.com □

Figure 5