

JRG/JT™ Models for Heating Liquids

Operating specifications

Model	MLE	MLH	ULJ	TLA
Heating Process	In-line	In-line	In-line	In-tank
Max Temp Rise (°F)	180	215	200	125
Maximum Flow Heated (GPM)	5000	5000	700	4000
Steam Press Range (PSIG)	Vac-45	Vac-120	0-150	1-140

Using Eductors for Direct Condensation of Steam into Liquids

Eductor liquid heaters operate by condensing steam into the liquid that is being heated. The process ensures a complete transfer of the BTUs in the steam to the liquid. The steam gives up its BTUs as it condenses into the liquid. This also dilutes the motive liquid with the condensate. Eductor liquid heaters function under the normal principles of eductors. In actuality, the process is that of a liquid pumping a gas. To better understand liquids pumping gases, refer to JRG/JT Technical Guide 700-310. The only thing that differs with pumping steam as a suction fluid is the increased affinity of steam for cold water. Because of this affinity, a greater volume of steam is pumped under the same conditions. Also, in some cases, the BTUs being released allow the unit to discharge to higher pressures than either the motive or the suction pressure. (See performance tables to determine actual service conditions.)

jrgjt.com

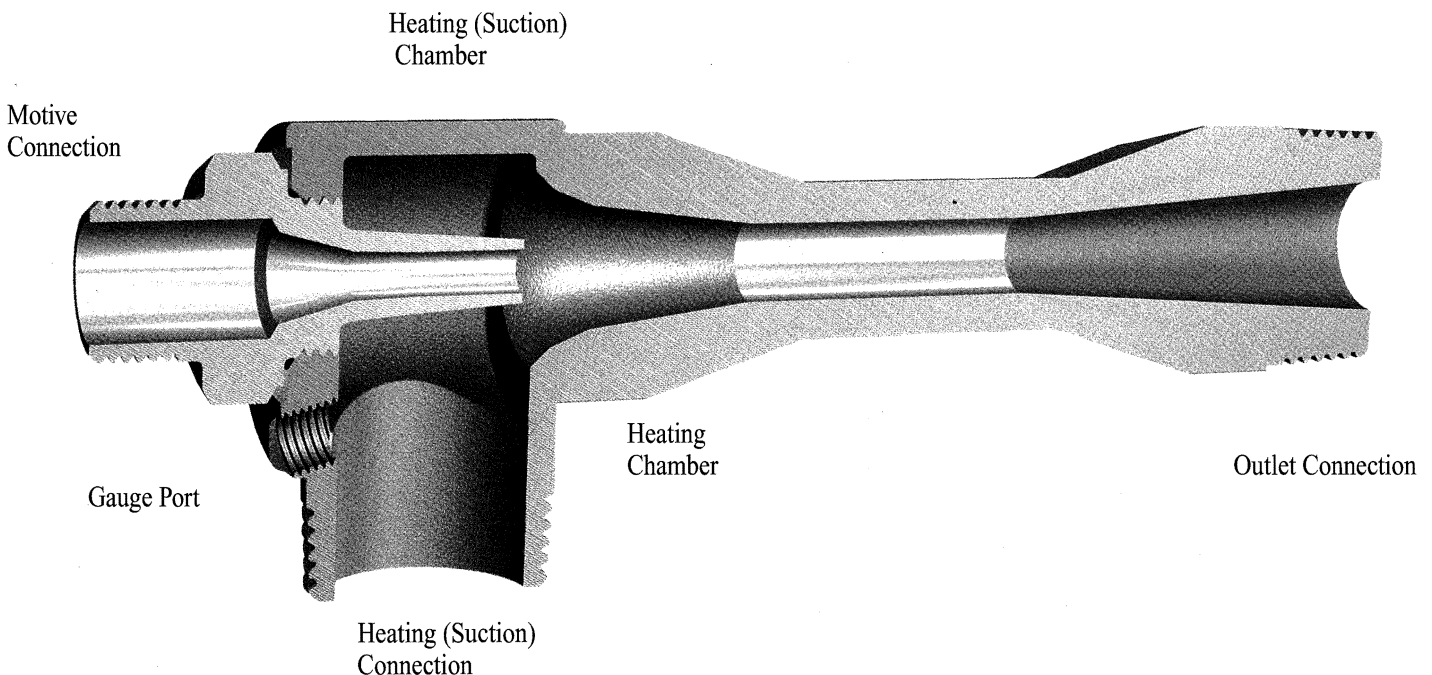

How to Size Eductors for Heating Liquids

Eductor liquid heaters have three service connections that will affect the performance of the units. The actual conditions at these connections should be clearly specified to ensure correct operation. The motive is the connection where the liquid to be heated enters the eductor. The heating (steam) is the connection where the steam enters the eductor. The discharge connection is where the heated fluid exits the eductor.

Motive (Liquid) Connection

At this connection, the liquid to be heated enters the eductor. In most instances, the liquid is under pressure at this point. As it passes through the nozzle, the pressure is converted to a high velocity stream that passes into the heating chamber. The velocity of the motive liquid in the heating chamber allows the steam to be drawn into the liquid to be heated.

Heating (Steam) Connection

The entrainment of steam into the liquid begins as the high velocity liquid stream draws the gas (steam) into the heating chamber as it passes through the chamber. This lowers the pressure in the heating chamber, allowing more steam to be pushed into this area. As the steam is entrained into the high

velocity liquid, its BTUs are released into the fluid, heating the liquid. The resulting mixture is pushed by momentum toward the outlet connection of the eductor.

Outlet Connection

As the condensed steam and liquid mixture go through the eductor, the energies of the two fluids are combined. This combination and the relative percentage of each fluid will have a great effect on the amount of pressure that can be recovered at the outlet of the eductor. Unlike other eductor applications, the heater generally has a positive power input on both incoming ports. In the case of the liquid motive, this power is from the pressure of the incoming liquid. In the case of the heating steam, this power can come from the pressure of the incoming steam and/or from the internal energy of the steam being released as it condenses. The percentage of each fluid entering the eductor and how both are mixed will determine how much back pressure can be tolerated. In the event of high discharge pressures, the eductor must be started and reach a state of equilibrium before the maximum discharge pressure can be handled. In most cases, this requires the installation of a bypass valve for start up.

Typical Liquid Eductor Heater Units

Jerguson/Jacoby-Tarbox makes several types of liquid heating eductors that are designed to heat over a variety of conditions. Because of the diversity of applications for the units, the motive and heating ports may be in different locations. It is important for proper operation of the units that the liquid and steam be connected to the proper ports. The following JRG/JT models of eductors can be used in heating applications: ULJ, MLE, and MLH. On all of these units the liquid to be heated enters the motive connection.

Where can Liquid Heating Eductors be Used?

Eductors have been used to successfully heat liquids in many industries and processes. The units can heat in-line or in-tank to achieve results that will improve your process. These units are used in the following industries: Pulp and Paper, Chemical, Petroleum, Dairy, Agriculture, and Breweries. Typical applications include: sterilization, cooking, heated wash down sprays, heating solutions, pasteurization in-line, mixing while heating, activating temperature controlled substances, and maintenance of tempering vessels.

Why are JRG/JT eductors chosen for Heating applications?

Small physical size	Heating done completely within piping systems.
Low cost of installation	Foundations and wiring are not required.
Intergal Gage Ports	Enables rapid troubleshooting.
No moving parts	Reduced maintenance.
ASME/ANSI B16.5 Rating	Enables ANSI rating of entire systems.
No packing glands	Reduced maintenance.
Lubrication is not required	Reduced maintenance.
Body as strong as piping	Handles normal piping stresses.
Wide variety of connection types available	Male/Female NPT, Butt/Socket Weld, Flanged, Silbraze, Victaulic
Properly installed eductors require few shutdown procedures	Ease of control for intermittent operations
Hex mounting on body	Easy mounting to piping.
Low relative cost for exotic materials	The no moving parts feature makes it easy and quick to obtain exotic materials. These materials will not affect the performance of the units.
Longer service life	The lack of moving parts means many units will operate for years without affecting performance.
O-Ring sealed body/nozzle joint	Bubble tight seal, easy effective maintenance.
Use of sources normally considered waste	In many cases, steam can be used for heating with pressures as low as 1 or 2 PSIG. This allows you to gain value from a resource normally vented or returned to your boiler.
Smooth body flow passages	High efficiency and flows.
Economical use of waste steam	Low pressure steam still contains substantial heating value, all of which is used.

How to Use Eductors for Heating in Process Lines Using Liquid as the Motivating Stream

The following models of Jerguson/Jacoby-Tarbox eductors can be used as heating devices using a pressurized liquid as the motive force for the process: MLH, MLE, ULJ. These units operate over a variety of conditions.

The models MLE and MLH will pull more steam for a given set of pressure conditions. They require a larger pressure drop through the eductor, but it results in a higher temperature rise through the eductor per pass. These units are generally used when the system requires a single pass through the eductor. If they are operated intermittently, the pressure drop will increase when the steam is shut off. When using low pressure steam for heating, it is recommended that the motive liquid temperature in these units not exceed 100°F. Higher incoming temperatures should be thoroughly evaluated to avoid objectionable noise and water hammer. To determine the actual operating parameters of each unit, refer to the performance table for that unit.

The model ULJ generally requires a steam pressure greater than the liquid pressure being used. It also produces less pressure

drop on the liquid, but there is a lower temperature rise for the liquid medium, as the lower steam flows contain less total BTUs. These models are designed so that they can be used on a multiple pass system. Many times these units are used to heat jackets on reactors or other systems where low pressure drops in the liquid lines are required or where a small temperature increase per pass is required. The lower amount of steam injected per pass allows these units to heat to higher final temperatures. Also, the liquid pressure drop remains small in these units when the steam flow is shut off.

The units, listed in general order of largest to smallest temperature rise and pressure drop, are: MLE, MLH, ULJ. These units are available for use to heat in-line, producing hot liquids for spray cleaning operations, heating liquids for jacketing on reactors or heat exchangers, cooking or sterilizing in-line.

When used with a temperature probe and a steam control valve, the eductor will result in an almost instant temperature adjustment. The lag time of the temperature probe and valve will affect the performance of the system lag more than the eductor itself.

General Rules for Selecting Eductors

Is the steam pressure lower than the liquid pressure? If the answer is yes, choose one of the following eductors: MLE, MLH. These units will function pulling a low pressure steam into a higher pressure liquid stream.

If the unit is to be used on a recirculating stream, consider the ULJ unit.

If the steam pressure is higher than the liquid, consider the ULJ.

If low pressure drop is allowed on the liquid stream, consider the ULJ.

MLE, MLH, ULJ		Sizing Factors (S.F.)											
Unit Size	1/2"	3/4"	1"	1-1/4"	1-1/2"	2"	2-1/2"	3"	4"	6"	8"	10"	12"
S.F.	0.12	0.21	0.34	0.61	1.00	1.82	3.17	5.92	11.8	24.0	49.0	71.0	123.0

How to Size Eductors for In-Line Heating

All eductors heat by condensing steam into the liquid being heated. Due to differences in the design of each eductor, performance will vary for different models. A set of general rules is provided to calculate the amount of steam needed to heat any flow of liquid. To calculate the approximate steam flow required, some of the correction factors will be ignored. If a precise number is needed for the consumption of steam, use a steam table to determine the exact BTUs per Lb of steam. In general this will effect the calculation less than 3%.

Formulas:

$$Q_s = Q_m \times 8.33 \times \Delta T / 1100 \text{ BTU/Lb}$$

$$\Delta T = Q_s \times 1100 / Q_m \times 8.33$$

Terms For Formula:

- Qs = Steam flow in Lb/Min required to heat liquid
- Qm = Liquid flow in GPM
- Sg = Specific gravity of inlet liquid
- 8.33 = Density of water in Lb/Gal. If the specific gravity or specific heat of the liquid is different from 1, multiply 8.33 by the actual values to correct the calculation.
- ΔT = Differential temperature in degrees F
- 1100 = BTUs per Lb of steam average. If a more accurate number is required, calculate this number from a set of steam tables.

Parameters Required to Size an Eductor

Liquid Inlet Conditions

- What is the Liquid?
- Liquid Pressure
- Incoming Liquid Temperature
- Liquid Flow
- Desired Temperature Rise

Heating or Steam Inlet

- Steam Pressure
- Steam Quality (is it saturated or superheated?)

Outlet

- Maximum Outlet Pressure
- Desired Outlet Temperature

Procedures for Sizing MLE, MLH Eductors for In-line Heating

Step 1 Calculate the amount of steam required to heat your liquid flow. Use the calculation $Q_s = Q_m \times 8.33 \times \Delta T / 1100$

Step 2 Locate the row on the MLE or MLH performance table (Page 5) that corresponds to the liquid motive pressure. Follow the row selected until the temperature rise meets or exceeds your desired temperature rise.

Step 3 Take the motive liquid flow desired, divide by the flow given in the table located 2 lines below the temperature rise chosen in Step 2. This will give a Desired Sizing Factor (S.F.). Choose the eductor size that meets or exceeds the estimated S.F. from the S.F. table (Page 3).

Step 4 Determine if the steam pressure at this point is equal to or less than the steam pressure available.

Step 5 Check the outlet pressure at this point to be sure it meets or exceeds your required outlet pressure. (This is the outlet pressure with the steam running. If this is an intermittent heating operation, use the outlet pressure listed with the steam at 0 PSIG.)

Example:

Motive Flow Qm	90 GPM
Motive Pressure	60 PSIG
Motive Temperature	80°F
Heating (Steam) Pressure	100 PSIG
Steam Condition	Saturated
Outlet Pressure	30 PSIG
Desired Outlet Temperature To	150°F
Desired Temperature Rise ΔT=150-85	= 65°F

Step 1 $Q_s = 90 \times 8.33 \times 65 / 1100$
 $Q_s = 44.3 \text{ Lb per Min. Steam}$

Step 2 In the model MLH at 60 PSIG and 65°F temp. rise the 1-1/2" unit flows 30 GPM of inlet liquid.

Step 3 S.F. = 90/30
 S.F. = 3.0
 In this case, the MLH 2-1/2" with a S.F. of 3.17 should be chosen.

Step 4 Is the steam pressure at this point less than the steam pressure available? If not, examine another unit. This is less than the 100 PSIG available.

Step 5 The outlet pressure in the performance table at this point reads 50 PSIG. This exceeds the required 30 PSIG.

Calculations of Actual Performance:

For MLH 2-1/2" chosen above
 $Q_m = 29 \text{ (from Table)} \times 3.17 \text{ S.F.} = 91.9 \text{ GPM}$
 $Q_s = 15.6 \text{ (from Table)} \times 3.17 \text{ S.F.} = 49.4 \text{ Lb /min steam}$
 $\Delta T = (49.4 \times 1100) / (91.9 \times 8.33) = 71.0^\circ\text{F}$

As you can see, the performance of the actual unit will vary slightly from the calculated sizing. If the 71° is too much, the steam pressure may need to be reduced to achieve proper performance.

Procedures for Sizing ULJ Eductors for In-Line Heating

If using a ULJ, the amount of liquid flow is determined by the pressure drop (ΔP).

Step 1 Calculate the amount of steam required to heat the liquid flow. Use the following calculation $Q_s = Q_m \times 8.33 \times \Delta T / 1100$.

Step 2 Locate the row on the ULJ performance table (Page 5) that corresponds to the liquid pressure. Move across this row until under the column which represents the steam pressure that is equal to or lower than your actual pressure available (Ps). This is your steam flow.

Step 3 Take the steam flow desired (Qs) divided by the flow from the table found in Step 2. This will give a Desired Sizing Factor (S.F.). Choose the eductor with a Tabulated S.F. (Page 3) that meets or exceeds the Desired S.F.

Step 4 To determine the outlet pressure (Po), calculate the pressure drop (ΔP) using the formula below and the S.F. selected in Step 3. Subtract the ΔP from the pressure at the motive connection (Pm). The result is the outlet pressure (Po).

Step 5 To determine the actual temperature rise ΔT (°F), use the formula below with actual motive and suction flows (GPM) as the input values.

Formula's

$$\Delta P = (Q_m / (14.14 \times S.F.))^2$$

$$\Delta T = Q_s \times 1100 / Q_m \times 8.33$$

How to Heat Liquids in Vessels

There are many advantages to using educutors for heating liquids in open vessels. These give the vessel heating educutor a place as a viable option for heating in many types of vessels.

The educutor heater provides direct contact of the steam into the liquid. This assures complete transfer of the energy in the steam into the liquid being heated. Other types of heating lose efficiency as the interior of the heat exchanger builds up a scale. With educutors, the velocity of the steam being injected into the vessel also causes the liquid contents of the vessel to be agitated while heating occurs, without the need for other types of mixers in the vessel. This provides for more even heating of the vessel contents. They also permit the steam to be dispersed over more of the liquid volume, resulting in a more homogenous heating than with other methods of injecting steam.

These designs of educutors allow steam to be used from 10 to 140 PSIG for heating. Because of the nature of direct steam injection, heating vessels at atmospheric pressure beyond 140°F should not be attempted. Exceeding this temperature could result in uncondensed steam evolving from the liquid.

Models for Heating Vessels

The standard Jerguson/Jacoby-Tarbox models for heating in vessels are the TLA and ULJ. The model TLA is well suited to providing strong tank agitation while heating. Compared with other heaters, the cost per application is small. The model ULJ is designed to provide vigorous circulation of the liquid with low pressure steam inputs.

TLAs should be located with the outlet pointed toward the most remote portion of the tank to provide the best agitation possible.

Sg = Specific gravity of tank liquid

Sh = Specific heat of tank liquid

How to Size Educutors for Heating Vessels

Information needed to size includes the following:

What is the tank liquid? (If it is not water (Sg = 1.0, Sh = 1.0), contact your representative.)

What temperature rise (ΔT) is needed?

What is the final tank temperature?

What is the vessel capacity?

Time available to heat the vessel (t)?

Steam pressure available?

Step 1 To determine the amount of steam required to heat the liquid in the vessel, multiply the gallons in the vessel to be heated x 8.33 x Sg x Sh x temperature rise ΔT desired, divided by 1100 (BTUs per Lb steam).

Lb steam required (Wm) = Gal x 8.33 x Sg x Sh x ΔT /1100

Step 2 To calculate the flow of steam required per minute, divide the steam flow from Step 1 by the time you need to complete the heating process.

Lb steam per minute (Qm) = Wm/minutes (t)

Step 3 If multiple units are going to be used, divide the number from Step 2 by the number of units to be used.

Step 4 Go to the TLA Steam Flow table (on Page 7). Find the amount of steam flow Qm (Lb/Min) at the steam pressure available. This is the steam flow for a 1-1/2" unit. Take the steam flow obtained in Step 3 divided by the steam flow from the Steam Flow table. This will give the Sizing Factor (S.F.) needed to heat the vessel in the time required.

S.F. = Desired Steam Flowrate/Tabulated Steam Flowrate

Step 5 Choose the educutor size that has S.F. that meets or exceeds the number determined in Step 4.

Example:

The liquid in the vessel is *Water* (Sg = 1.0)
The temperature rise desired is $\Delta T = 50^\circ F$
The final tank temperature is $120^\circ F$
The vessel holds *550 Gal*
The time to heat it is *20 Min*
Steam is available at *40 PSIG*
Use two educutors

Step 1 $Wm = 550 \times 8.33 \times 1.0 \times 50/1100 = 208$ Lb of steam required

Step 2 $Qm = \text{Lb steam per minute} = 208/20 = 10.4$ Lb steam per minute

Step 3 Are multiple units going to be used? If so how many? In this case, we will use two educutors. $10.4 \text{ Lb steam per minute}/2 = 5.2$ Lb/min per educutor

Step 4 $S.F. = 5.2/13.4 = .39$ desired S.F.

Step 5 Choose the model TLA 3/4" with a S.F. of .50 as this is the smallest unit that meets or exceeds the desired S.F.

Calculating Actual Performance

$Qm \text{ per unit} = 13.4 \times .50 = 6.7$ Lb/Min
 $Qm \text{ for installation} = 6.7 \times 2 = 13.4$ Lb/Min
Time to heat tank = $208 \text{ Lb (Step 1)}/13.4 = 15.5$ minutes

If two TLAs 3/4" are installed and operated at 40 PSIG of steam pressure, they will heat the liquid in 15.5 minutes.

TLA Performance Tables

TLA	Steam Flow, Qm (Lb/Min)								1 - 1/2" Unit
	Steam Pressure, Pm (PSIG)								
	10	20	40	60	80	100	120	140	
Steam Flow, Qm(Lb/Min)	6.4	8.8	13.4	18.3	22.8	27.4	31.9	36.5	

TLA	Sizing Factors (S.F.)				
Unit Size	3/8"	3/4"	1-1/2"	2"	3"
S.F.	0.25	0.50	1.00	2.00	4.60

TLA	Volume of Liquid Heated per minute, Qm (GPM)									
	Size	Temp Rise ΔT	Steam Pressure, Pm (PSIG)							
			10	20	40	60	80	100	120	140
3/8"	25	8.5	11.6	17.7	24.2	30.1	36.2	42.1	48.2	
	50	4.2	5.8	8.8	12.1	15.1	18.1	21.1	24.1	
	75	2.8	3.9	5.9	8.1	10.0	12.1	14.0	16.1	
	100	2.1	2.9	4.4	6.0	7.5	9.0	10.5	12.0	
	125	1.7	2.3	3.5	4.8	6.0	7.2	8.4	9.6	
3/4"	25	16.9	23.2	35.4	48.3	60.2	72.4	84.2	96.4	
	50	8.5	11.6	17.7	24.2	30.1	36.2	42.1	48.2	
	75	5.6	7.7	11.8	16.1	20.1	24.1	28.1	32.1	
	100	4.2	5.8	8.8	12.1	15.1	18.1	21.1	24.1	
	125	3.4	4.6	7.1	9.7	12.0	14.5	16.8	19.3	
1-1/2"	25	33.8	46.5	70.8	96.7	120.4	144.7	168.5	192.8	
	50	16.9	23.2	35.4	48.3	60.2	72.4	84.2	96.4	
	75	11.3	15.5	23.6	32.2	40.1	48.2	56.2	64.3	
	100	8.5	11.6	17.7	24.2	30.1	36.2	42.1	48.2	
	125	6.8	9.3	14.2	19.3	24.1	28.9	33.7	38.6	
2"	25	67.6	93.0	141.6	193.3	240.9	289.5	337.0	385.6	
	50	33.8	46.5	70.8	96.7	120.4	144.7	168.5	192.8	
	75	22.5	31.0	47.2	64.4	80.3	96.5	112.3	128.5	
	100	16.9	23.2	35.4	48.3	60.2	72.4	84.2	96.4	
	125	13.5	18.6	28.3	38.7	48.2	57.9	67.4	77.1	
3"	25	155.5	213.8	325.6	444.6	554.0	665.8	775.1	886.9	
	50	77.8	106.9	162.8	222.3	277.0	332.9	387.5	443.4	
	75	51.8	71.3	108.5	148.2	184.7	221.9	258.4	295.6	
	100	38.9	53.5	81.4	111.2	138.5	166.4	193.8	221.7	
	125	31.1	42.8	65.1	88.9	110.8	133.2	155.0	177.4	

Dimensions

Model ULJ

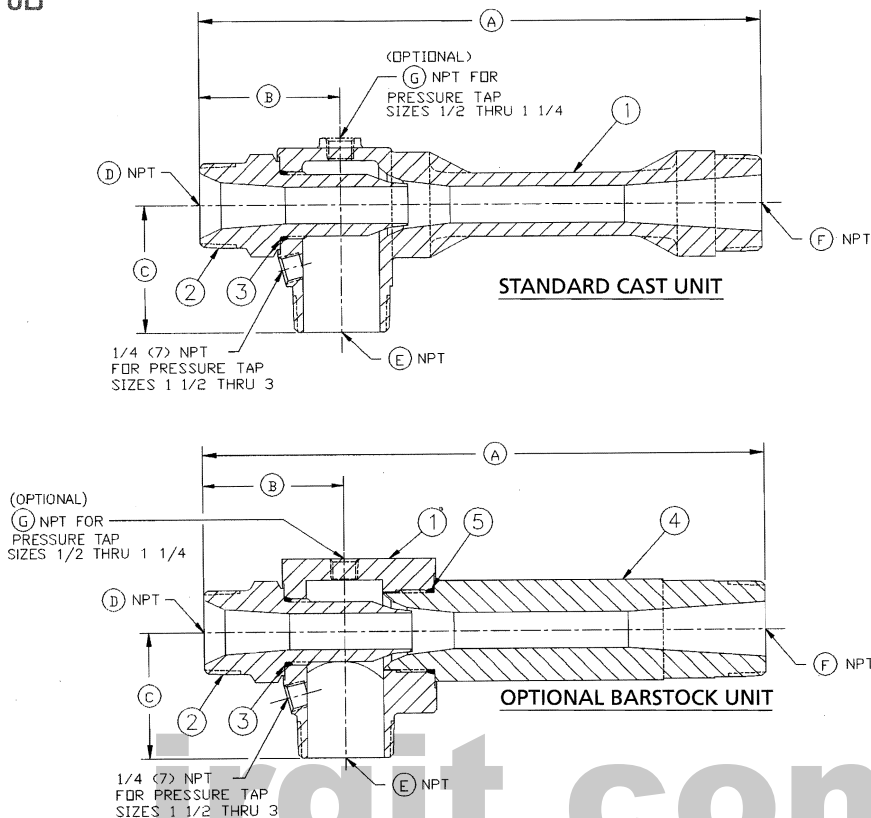

Parts List	
ITEM	DESCRIPTION
1	BODY
2	NOZZLE
3	O-RING, NOZZLE
4	DISCHARGE
5	O-RING, DISCHARGE

ULJ Assembly Dimensions

SIZE	Inches (mm)						
	A	B	C	D	E	F	G
1	7.125 (181)	2.250 (57)	1.750 (44)	3/4 (30)	1 (25)	1 (25)	1/4 (7)
1 - 1/4	9.000 (229)	2.500 (64)	2.250 (57)	1 (25)	1 - 1/4 (32)	1 - 1/4 (32)	1/4 (7)
1 - 1/2	11.000 (279)	2.750 (70)	2.500 (64)	1 - 1/4 (32)	1 - 1/2 (40)	1 - 1/2 (40)	-
2	14.375 (365)	3.125 (79)	3.000 (76)	1 - 1/2 (40)	2 (50)	2 (50)	-
2 - 1/2	18.125 (460)	3.500 (89)	4.125 (105)	2 (50)	2 - 1/2 (65)	2 - 1/2 (65)	-
3	23.875 (606)	4.000 (102)	5.000 (127)	2 (50)	3 (80)	3 (80)	-

OPTIONAL CONNECTIONS FOR MOTIVE, SUCTION AND OUTLET CONNECTIONS

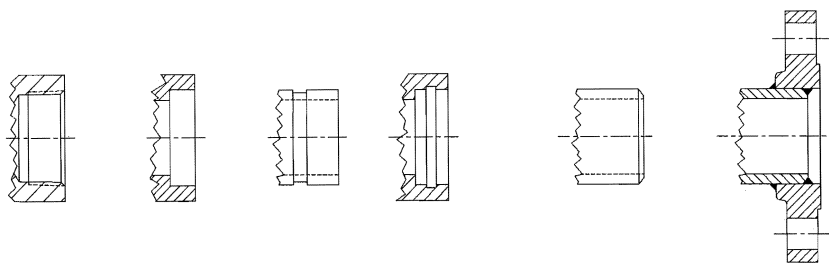

FEMALE NPT SOCKET WELD VICTAULIC SILBRAZE SCH 80 BUTT WELD 150# FLANGE

NOTE: OPTIONAL CONNECTIONS WILL INCREASE A, B, AND/OR C. CONSULT FACTORY FOR DETAILS.

Dimensions

Model MLE, MLH

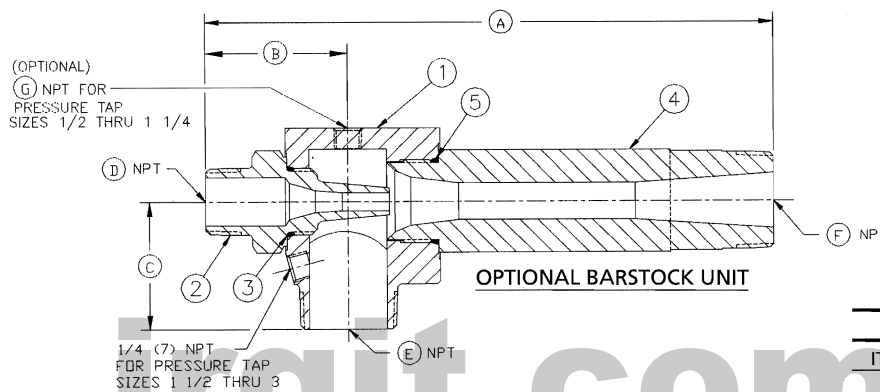
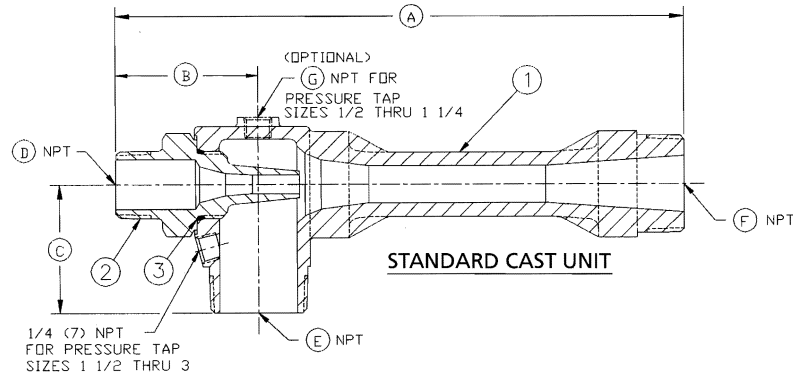

Parts List

ITEM	DESCRIPTION
1	BODY
2	NOZZLE
3	O-RING, NOZZLE
4	DISCHARGE
5	O-RING, DISCHARGE

MLE, MLH

Assembly Dimensions

SIZE	Inches (mm)									
	A	B	C	D	E	F	G			
1/2	4.500 (114)	1.625 (41)	1.250 (32)	3/8 (10)	1/2 (15)	1/2 (15)	1/8 (3)			
3/4	5.875 (149)	2.000 (51)	1.500 (38)	1/2 (15)	3/4 (20)	3/4 (20)	1/4 (7)			
1	7.125 (181)	2.250 (57)	1.750 (44)	3/4 (20)	1 (25)	1 (25)	1/4 (7)			
1 - 1/4	9.000 (229)	2.500 (64)	2.250 (57)	1 (25)	1 - 1/4 (32)	1 - 1/4 (32)	1/4 (7)			
1 - 1/2	11.000 (279)	2.750 (70)	2.500 (64)	1 (25)	1 - 1/2 (40)	1 - 1/2 (40)	-			
2	14.375 (365)	3.125 (79)	3.000 (76)	1 - 1/4 (32)	2 (50)	2 (50)	-			
2 - 1/2	18.125 (460)	3.500 (89)	4.125 (105)	1 - 1/2 (40)	2 - 1/2 (65)	2 - 1/2 (65)	-			
3	23.875 (606)	4.000 (102)	5.000 (127)	2 (50)	3 (80)	3 (80)	-			

OPTIONAL CONNECTIONS FOR MOTIVE, SUCTION AND OUTLET CONNECTIONS

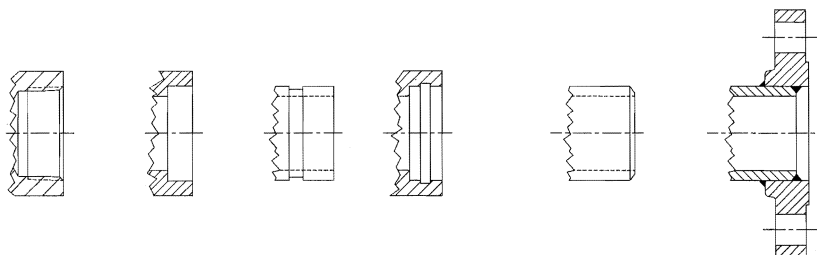

FEMALE NPT SOCKET WELD VICTAULIC SILBRAZE SCH 80 BUTT WELD 150# FLANGE

NOTE: OPTIONAL CONNECTIONS WILL INCREASE A, B, AND/OR C. CONSULT FACTORY FOR DETAILS.