

Northeast Controls Incorporated

Installation Operating and Maintenance Instructions

JERGUSON FLAT GLASS GAGES

***** DOWNLOAD THIS DOCUMENT FROM OUR WEBSITE *****

Specialists In Liquid Level Indication

Flat Glass Gages



Jerguson Flat Glass Gages are simple, rugged instruments engineered and constructed throughout to give you accurate liquid level readings for the life of the vessel - with a complete range of models for any application from pure water to highly corrosive chemicals and from cryogenic fluids to superheated steam. Like any instrument, Jerguson flat glass gages must be installed, operated, and maintained with reasonable care and due regard for the application and environment if they are to give accurate readings over a long life.

Inspection and Delivery

Upon receiving gage, check all components carefully for damage incurred in shipping. Notify shipping firm immediately of any such damage, and request damage inspection. Confirm that gage model number and pressure/temperature ratings (stamped on nameplate) meet application specifications. Also confirm that gage material is compatible with both process fluid and surrounding atmosphere in your application. Caution: Jerguson Gage Glasses are not to be used for gaging lethal substances as defined by ASME Section VIII.

BEFORE YOU INSTALL THE GAGE

...you should consider the following:

- To avoid imposing piping strains on the gage chamber, connect and mount the gage so that it does not support the piping.
- Differential thermal expansions between the vessel and gage can impose severe mechanical loads on the gage— especially if the vessel contains hot or cryogenic liquids. To prevent these, install an expansion loop between gage and vessel or use a reasonably long run of piping.
- Support brackets should be considered for gages over four feet in length or over 100 pounds in weight, especially when the gage is exposed to vibration. These support brackets will prevent overloading the connecting valves and piping and prevent damage to the gage from excessive vibration.
- Always provide shutoff valves between gage and vessel. Jerguson automatic ball check valves are recommended to help provide protection against physical injury and loss of product if glass breakage should occur. Such valves also provide a means to isolate the gage for maintenance.

Upper Saddle River, New Jersey 07458 USA
201-327-7660 Fax: 201-327-3242
www.nciweb.net



- Bolt torque is vital to the proper operation of a liquid level gage. Because gaskets compress over a period of time, bolt torque should be checked before the gage is installed. (Ref. to maintenance). Bolt torque should also be checked after the first few hours of operation.

CAUTION: Gages should always be isolated from the process system by closing upper and lower valves, and drain gage to relieve pressure before doing any torque or maintenance checks.

OPERATION

CAUTION: Rapid opening of connecting valves can cause glass breakage and/or possible injury to personnel. Gages should be brought into service slowly.

Always warm up the gage slowly when it is used with a vessel containing hot fluid. Crack open the shutoff valves carefully, and wait until the gage is fully warmed up before opening them all the way. Actually, Jerguson gages are fitted with tempered glass that can withstand sharp thermal transitions—cold water to 500• F—without breaking; but additional loads that you cannot measure are imposed on the glass during installation, and resistance to thermal shock is reduced correspondingly.

During system shutdown, it is best to leave the shutoff valves open, the gage then cools and depressurizes along with the system.

Keeping valves closed during shut down can trap high pressure liquid in the gage.

For high pressure and/or temperature applications a viewing system of mirrors should be used to protect personnel from possible glass breakage.

Gages should be *isolated* periodically and bolt torque checked to prevent leaks. This is especially important on gages used in intermittent operation or varying service conditions. (See TIPS FOR SPECIAL APPLICATIONS.)

When putting a gage into service always check for leaks and be certain the shut-off valves are fully open with all vents and drains closed before leaving the site.

CAUTION: While the gage Glass is in operation, the shutoff valves must be in the fully open valve position. A partially open valve will prevent automatic ball checks from seating which could result in physical injury to personnel and loss of product.



MAINTENANCE

Tools for easy and correct maintenance of all flat glass gages and associated valves are contained in the special Jerguson Tool Kit. The heavy-duty olive drab twill tool case folds over and is tied compactly with tape for easy carrying or storage.

A. Inspection of Glass:

Look *at* the glass regularly for any signs of clouding or scratching. In new processes, the glasses should be inspected daily until the need for replacement becomes apparent; this will help establish the routine inspection cycle.

To examine for scratches, shine a very bright concentrated light ("Burton Lite", powerful flashlight, or automotive stoplight bulb) at about a 45° angle. Anything which glistens brightly should be looked at closely. Any scratch which glistens and catches fingernail, any star-shaped or crescent-shaped mark which glistens is cause for replacement. If inner (chemical) surface appears cloudy or roughened and will not respond to cleaning procedures, this is evidence of chemical attack and, if severe, is cause for replacement.

B. Cleaning of Glass:

Keep glasses clean using commercial glass cleaners (including Windex, Glass Wax, Bon-Ami, Lava Soap, Super Soilax, household detergents). Where regular cleaners do not seem to work, it is possible to use dilute acids such as Hydrochloric (muriatic) acid. Observe safety rules carefully when handling these dangerous chemicals. Cleaning should be done *without removing glass*; this may require recirculation of cleaning material if vessel side of glass is not accessible. Never use harsh abrasives, wire brushes, metal scrapers, or other things which could scratch the glass. DO NOT attempt to clean glasses while equipment is in operation.

C. Receiving and Storing Glass

Upon receiving glass inserts, inspect containers and glass inserts for shipping damage. Keep glasses in original boxes until ready to use. If ware is to be inspected, unwrap and wrap carefully, avoiding bumping or sliding polished face across any other object (including table tops).

D. Disassembly

Prior to any disassembly of the gage, first be sure that the gage is relieved of all internal pressure, and temperature is ambient. *Failure to do this may result in a sudden release of pressure and/or glass breakage.*

Loosen end bolts first, working from opposite ends toward the center.



E. Reassembly

Glass, Gaskets, and Cushions

Jerguson gages use molded borosilicate glass, tempered to increase its bending resistance. This glass has a low coefficient of expansion and is more resistant to thermal shock than other glasses. Nevertheless, like any glass it is much stronger in compression than it is in tension: you should be careful not to impose any bending on the glass or set up any local stresses. The following points should be observed to ensure long life:

Check with maintenance supervisor and engineer for the proper glass to be used in equipment. Check box and glass labels or marking against the equipment pressure and temperature ratings.

The glasses, gaskets, and cushions should not be re-used, even when they appear in perfect condition. Replace them with new ones. Chipped or scratched glass should not be used, because such defects become points of high stress concentration. Even though a used glass may look perfect, it is not as reliable as a new one. Best practice is to always use a new glass.

- The glass should be seated on a flat surface with a suitable gasket on the seating surface to avoid subjecting the glass to stress concentrations which result from poor loading. It should be clamped in place with a flat cover plate that is uniformly loaded, as described in Reassembly Procedures below.
- The glass should not be in contact with any metal surfaces; in service, temperature differences at points of contact will set up high loadings and may break the glass.
- Use gaskets as follows: Series 51 Gages—O-ring gaskets Series 40 Gages—1/32 inch thick sheet All others— 1/16 inch sheet
- For transparent gages used in steam service—protect the glass from steam erosion by inserting mica sheet between glass and gasket on the liquid side. (For special protective devices and procedures for cryogenic and corrosive chemical applications (see TIPS FOR SPECIAL APPLICATIONS).

To avoid leakage and stresses on the glass, we recommend that you use these procedures:

- Before reassembling, clean gage chamber seats thoroughly with a soft metal scraper (preferably brass), like the one furnished in the Jerguson Tool Kit. Be sure all burrs and bits of old gasket are removed. Gouged or scarred seats should be refinished in a milling machine (or you can return the chamber to the Jerguson factory for refinishing), since they cause low gasket compression and leakage.

Northeast Controls Incorporated



- Locate the glass centrally in seat and cover, to avoid glassmetal contact at the ends or sides. This is best done with the gage horizontal on a bench. If it must be reassembled in a vertical position, use a small strip of gasket material (included in Tool Kit) as a spacer at each end of the glass; the sketch shows how. This will prevent contact of glass with metal during assembly and in service.

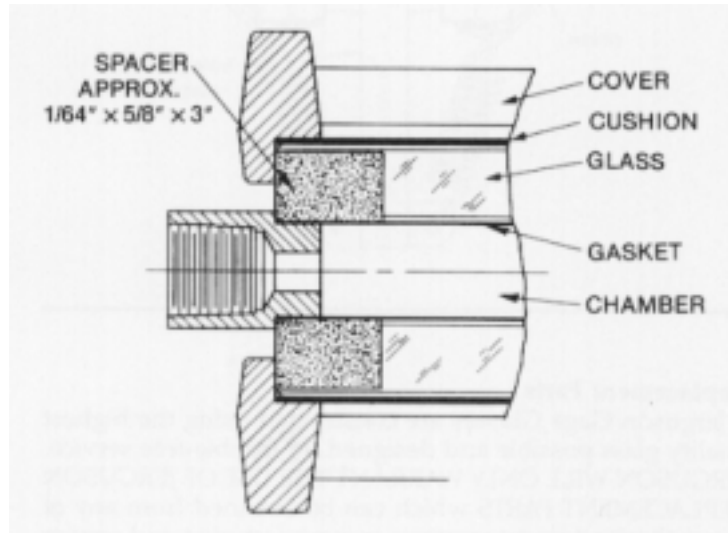

- With a torque wrench like that in the Jerguson Tool Kit, replace the gage covers as follows:
 - a. Clean bolt and nut threads and apply light oil to threads and the nut face. For gages operating at more than 150• F, use Molykote (supplied in tool kit) or a similar molybdenum disulfide lubricant.
 - b. Tighten nuts finger-tight in the sequence shown in the sketch, and then tighten with torque wrench in the same sequence, in five-pound stages; this procedure produces even loading of the glass.

CAUTION: While tightening the cover, be sure the gage is isolated from the vessel. Close valves between the pressure vessel and the gage glass and open the vent or drain on the gage glass to relieve the pressure.

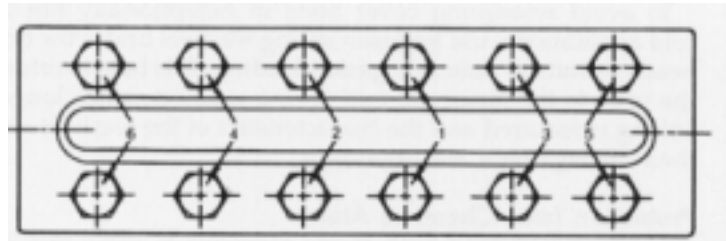

Sequence for Tightening

Cover Bolts

c. Recommended final torques are:

PROCESS GAGES

Gage Series

RL & TL- 10
 R & T-300L
 R & T- 18 (Sizes 6,7,8,9)
 R & T-18 (Sizes 4,5)
 R & T-20 (Sizes 3,6,7,8,9)
 R & T-20 (Sizes 1,2,4,5)
 R & T-30 & R & T-32
 R & T--40

Recommended Re-Torque Factory Assembled Gages at Initial Installation

20 Ft. Lbs.
 23 Ft. Lbs.
 23 Ft. Lbs.
 32 Ft. Lbs.
 23 Ft. Lbs.
 32 Ft. Lbs.
 40 Ft. Lbs.
 80 Ft. Lbs.

Gage Series

RL & TL- 10
 R & T-300L
 R & T-18 (Sizes 6,7,8,9)
 R & T- 18 (Sizes 4,5)
 R & T-20 (Sizes 3,6,7,8,9)
 R & T-20 (Sizes 1,2,4,5)
 R & T-30 & R&T-32
 R & T--40

Recommended Torque of Field Reassembled Gages

20 Ft. Lbs.
 23 Ft. Lbs.
 32 Ft. Lbs.
 32 Ft. Lbs.
 32 Ft. Lbs.
 32 Ft. Lbs.
 40 Ft. Lbs.
 80 Ft. Lbs.



- d. New rubber-bonded gaskets tend to become permanently compressed after a short time in service, especially if the gage operates hot; this causes slight leaks or apparent loosening of bolts. Therefore, retorque to the original value after the gage has been in hot operation for half an hour, using the same sequence as before.

Installation, Operating and Maintenance Instructions ~ Flat Glass Gages

- e. Recommended torque values in Paragraph C are based on the use of molybdenum disulfide lubricant and the use of rubber bonded asbestos gaskets cut to 3 appropriate dimensions for the particular gage series.
- f. Be sure that the replacement glass is proper for the service. Check safety devices for operation below pressure rating of the glass. Protective shields to keep cold air, water, or falling objects from glass, must be replaced.

TIPS FOR SPECIAL APPLICATIONS

Spring Washers for Temperature Extremes

To avoid retorquing cover bolts in exceptionally hot or cold applications, use Jerguson spring washers under the bolt heads or nuts to maintain gasket loading. It is best to return the gage to the factory to add spring washers, since longer bolting is required and the characteristics of the washers and their arrangement are important.

Protection from Chemical Attack

Gage glasses used with fluids corrosive to glass require the use of shields. Kel-F or Mica may be suitable to protect the glass. (Shields cannot be used with Reflex-Type glass inserts.) Mica Shields are installed between the sealing gasket and glass. Kel-F Shields are to be installed as follows:

- a) Place the Kel-F shield in the gage instead of a gasket between the chamber and glass inserts.
- b) Torque to the required torque level for the gage series in use.
- c) Let the gage sit for 10-12 hours.
- d) Retorque to original torque level as completed in Step b.
- e) Steps c and d may have to be repeated to prevent leakage.

Uniformly insulate the gage, so that all parts remain at the same temperature. Otherwise, thermal gradients may cause overloads on the glass or may relax the gasket clamping load and cause leaks.



Operation

To prevent thermal shock, bring the gage into service gradually; crack the shutoff valves to prevent a cold surge of liquid into the gage, and do not open them wide until the gage has time to cool down.

Do not isolate the gage when cold; the fluid within will warm up, the internal pressure will increase, and the gage may break. Either let the gage warm up with the system after shutdown, or if it must be isolated from the vessel, vent it to atmosphere.

If you must retorque at low temperatures to stop leaks, retorque the minimum amount required for the purpose. The torque tends to increase as the gage warms up, and excessive torquing when cold may overload the glass when it is restored to ambient temperatures. The use of Jerguson stainless steel spring washers (described above) may solve this problem.

High Temperature Service (over 500°F)

To prevent damage from high stresses resulting from extreme temperature gradients within the glass, a mica shield may be installed on the outside of the glass. The shield has an insulating effect and protects the outer surfaces of the glass from the effects of rapid changes in ambient temperature or cold spray.

Low Temperature Service

Installation

A Non Frost Ext. may be installed on the Series 10L, 18, 20 and 32 gages, as shown in the sketch. Attachment is accomplished by placing the stainless steel hooks (4 per extension) around the cover bolts on the under side of the cover. In effect, the extension increases the distance from glass face to cryogenic fluid so the face remains warm enough to prevent frosting.

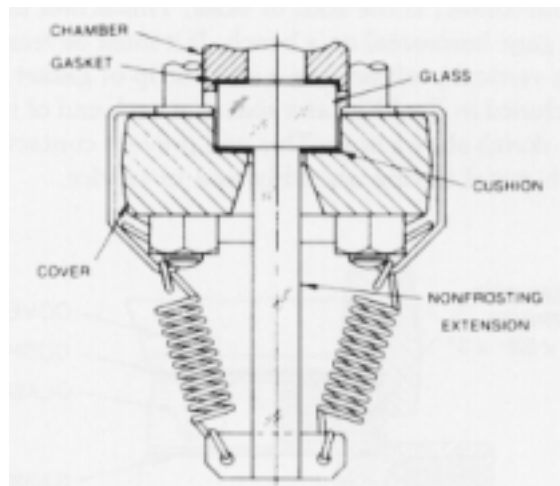



RECOMMENDED SPARE PARTS

Part	Commissioning	Two Year
Glass	5%	10%
Shields (if uses)	5%	10%
Gaskets	5%	10%
Cushions	5%	10%

Replacement Parts

Jerguson Gage Glasses are constructed using the highest quality glass possible and designed for trouble-free service. JERGUSON WILL ONLY WARRANT THE USE OF JERGUSON REPLACEMENT PARTS which can be obtained from any of our authorized representatives or manufacturing and service centers listed below:

Northeast Controls, Incorporated

123 Pleasant Avenue PO Box 275
Upper Saddle River, New Jersey 07458 USA
Tel: 201-327-7660 Fax: 201-327-3242

******* DOWNLOAD THIS DOCUMENT FROM OUR WEBSITE *******