

BILL OF MATERIAL

		66-1-01-A				66-1-01-T			
PIECE NO.	NAME OF PART	QTY.	MATERIAL	PART NO.	REMARKS	MATERIAL	PART NO.	REMARKS	
1	VALVE BODY	1	STEEL	V-956-A5	ASTM A105	316L SS	V-956-TL1	ASTM A182	
2	SEAT	1	416 SS	P-125-U3	QQ-S-763	316 SS	P-125-T2	QQ-S-763	
3	STEM	1	416 SS	S-121-U3	QQ-S-763	316 SS	S-121-T2	QQ-S-763	
4	SLEEVE	1	STEEL	P-182-A6	ASTM A108	316 SS	P-182-T2	ASTM A276	
5	NUT-SLEEVE	1	STEEL	P-70-6-A6	ASTM A108	STEEL	P-70-6-A6	ASTM A108	
6	PACKING RING	1	STEEL	P-254-1-A6	ASTM A108	316 SS	P-254-1-T2	QQ-S-763	
7	PACKING	4	GPH/NICR	G-259		GPH/NICR	G-259		
8	GLAND	1	STEEL	P-39-A6	ASTM A108	STEEL	P-39-A6	ASTM A108	
9	NUT-GLAND	1	STEEL	P-70-3-A6	ASTM A108	STEEL	P-70-3-A6	ASTM A108	
10	HANDWHEEL	1	MAL IRON	PD-325-D1		MAL IRON	PD-325-D1		
11	NUT-STEM	1	STEEL	P-78-6-A12	ASTM A563	STEEL	P-78-6-A12	ASTM A563	
12	TAILPIECE, 3/4" MALE ADJ.	1	STEEL	V-12009-A6	ASTM A108	316 SS	V-12009-T2	ASTM A276	
13	NUT-TAILPIECE	1	STEEL	P-70-48-A6	ASTM A108	STEEL	P-70-48-A6	ASTM A108	
14	BALL CHECK	1	440 SS	P-1-I		316 SS	P-1-T2		
15	BALL CHECK STOP	1	316 SS	V-13113-T		316 SS	V-13113-T		
16	RATING TAG	1	SS	V-8981-66		SS	V-18716-66		

NOTES:

1. VALVE RATING - CARBON STEEL & 316 SS
4000 PSI @ 100°F, 1500 PSI @ 75°F
2. TAILPIECE CENTERLINE MAY BE POSITIONED A MAXIMUM OF 5/64" OFF THE VALVE CENTERLINE.

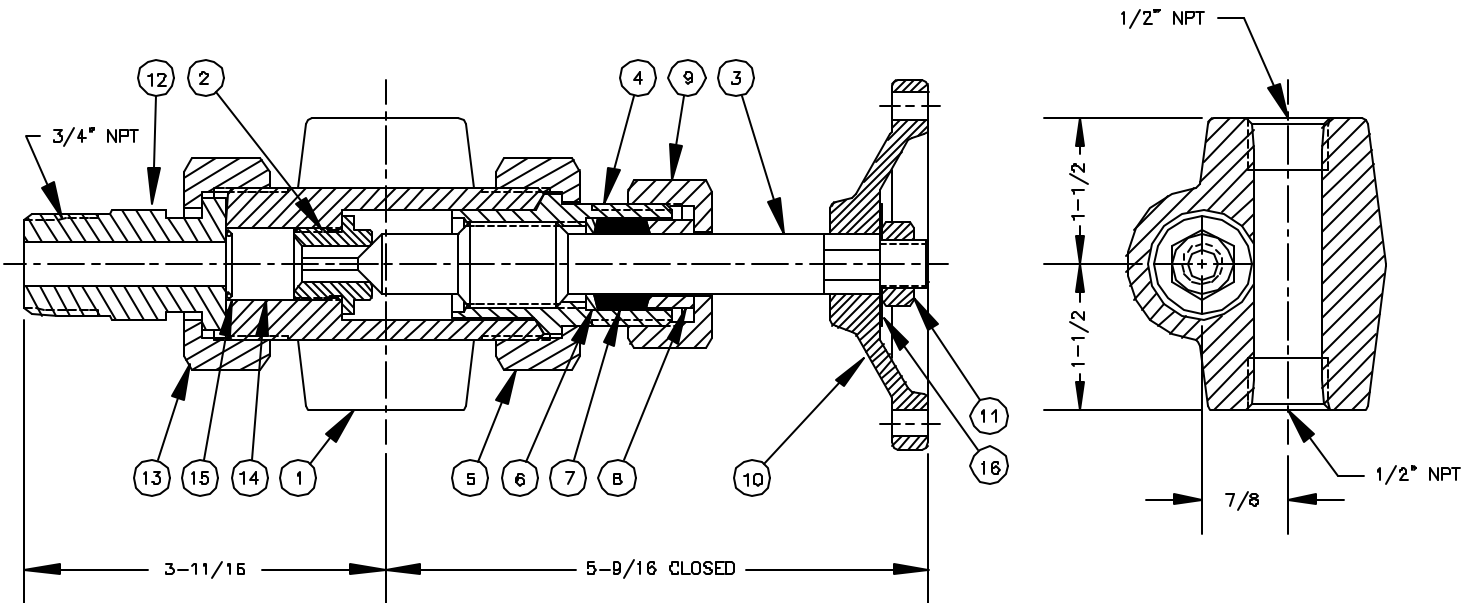

9	REDRAWN & UPDATED	7/7/98	
8	REDRAWN & UPDATED	7/15/96	
7	REDRAWN & UPDATED	3/15/96	
6	REDRAWN & UPDATED	8/8/92	
SYM	REVISION	DATE	APP

#66 VALVE P/C
UNION TANK CONN.

**JERGUSON
GAGE & VALVE CO.
STRONGSVILLE, OHIO, U.S.A.**

DRAWN TAP	FILE NO.
CHECKED MJK	DRAWING NO.
APPROVED	66-1-01
SCALE NONE	DATE 7/7/98
REV. 8	