

MATERIAL: SEE B/M  
 DRAWN: TFK  
 CHECKED: DEP  
 SCALE: NONE  
 DATE: 9-15-95



SIGHT FLOW INDICATOR  
 STYLE 100-S(T), 200-S(T), 300-S(T)

Section: T400  
 Bulletin: T400.15  
 Date: 12/01/00  
 Supersedes: 11/10/98

150 PSIG MODELS

FILE NO.: T400-15.DWG

PARTS LIST

PIECE NO.	NAME OF PART	QUAN.	MATERIAL	COMMENTS
1	BODY	1	SEE BELOW	
2	RETAINER	2	SEE BELOW	
3	CUSHION	2	FIBER	
4	SEAL GASKET	2		
5	WINDOW	2	BOROSILICATE	
6	INDICATOR	1		

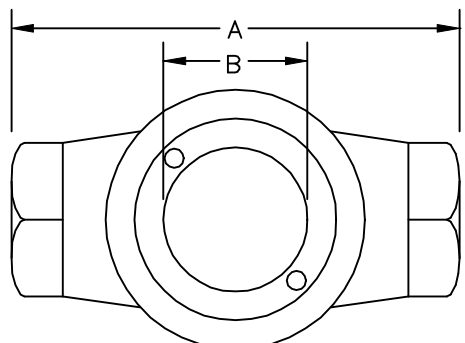

INDICATOR OPTIONS ⑥

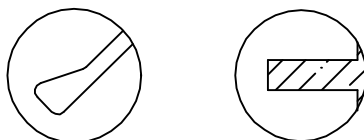

FLAPPER  PTFE FLUTTER   
 STYLE 100-S(T) STYLE 100-S-FLTR(T)

\*THE NEW 2" "ST" (STL & 316SS ONLY) HAS A THREADED RETAINER AND WILL BE USED FOR ALL 2" UNITS ORDERED

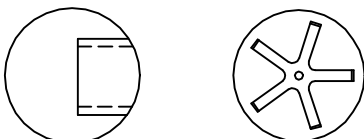

DRIP TUBE  PTFE ROTOR   
 STYLE 200-S(T) STYLE 300-S(T)



STANDARD DESIGN MATERIALS:

- BODY: ASTM A-216 WCB (CARBON STEEL)
- ASTM A-351 CF8M (316 SS)
- ASTM B-62 (BRONZE)
- ASTM A-126 CLASS B (CAST IRON)

- RETAINER: ASTM B16 H02 UNS C36000 (BRASS)
- RETAINER: ASTM A278 CLASS 30 (IRON) (2" ONLY)

INDICATOR: 316 SS FLAP&DRIP , PTFE FLUTTER&ROTOR

OPTIONAL ALLOYS FURNISHED UPON REQUEST

316 SS TRIM AVAILABLE

SEE "-SFA" (T400.16) FOR 2" BRONZE & IRON UNITS

PRESSURE/TEMP. RATINGS

TEMP F	150 PSIG MODELS		
	CS/316	BRONZE	IRON
-20 TO 100	150	150	150
150	150	150	150
200	150	150	150
250	150	150	150
300	150	150	150
350	150	150	150
400	150	150	140
450	150	N/R	N/R
500	150	N/R	N/R

OPTIONS

DUAL UNIGLAS WINDOWS



FULL VIEW DUAL WINDOWS



UNIGLAS WINDOW

PLAIN   
 STYLE 100-S (NF)

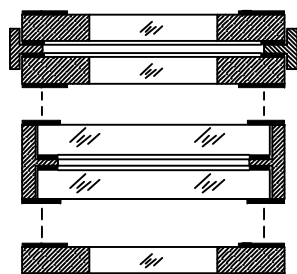

Factory Mutual System Approved

FNPT CONNECTIONS

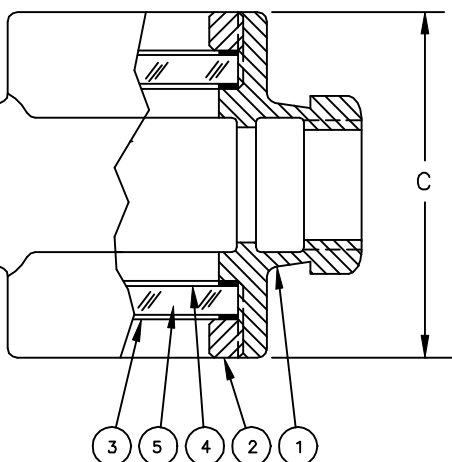

DIMENSIONS

PIPE SIZE	A		B		C		APPROX. WGT.	
	IN.	mm	IN.	mm	IN.	mm	LBS.	KGS.
1/8, 1/4, 3/8	3.00	76	.84	21	2.00	51	1.50	0.7
1/2 & 3/4	3.75	95	1.25	32	2.75	70	3.00	1.4
1	4.25	108	1.22	31	3.50	89	4.00	1.8
1-1/4 & 1-1/2	5.50	140	2.22	56	4.25	114	9.00	4
2 "ST"	6.25	159	2.22	56	CASTING DWG		11	5.1

THIS DRAWING AND ALL INFORMATION ON IT IS THE PROPERTY OF JACOBY-TARBOX, DIVISION OF THE CLARK-RELIANCE CORPORATION. IT IS CONFIDENTIAL AND IS GIVEN TO YOU FOR A LIMITED PURPOSE AND MUST BE RETURNED UPON REQUEST. NEITHER THIS DRAWING NOR ANY PART OF IT NOR ANY INFORMATION CONCERNING IT MAY BE COPIED, EXHIBITED OR FURNISHED TO OTHERS NOR MAY PHOTOGRAPHS BE TAKEN OF ANY ARTICLE FABRICATED OR ASSEMBLED FROM THIS DRAWING WITHOUT CONSENT OF THE CLARK-RELIANCE CORPORATION.