

MATERIAL: SEE B/M
 DRAWN: TFK CHECKED: DEP
 SCALE: NONE DATE: 09/15/97



SIGHT FLOW INDICATOR
 STYLES F-910HPA-600
 F-608HPA-600

Section: T400
 Bulletin: T400.05
 Date: 12/01/00
 Supersedes: 11/10/98

600 ASME CLASS MODELS

FILE NO.: T400-05.DWG

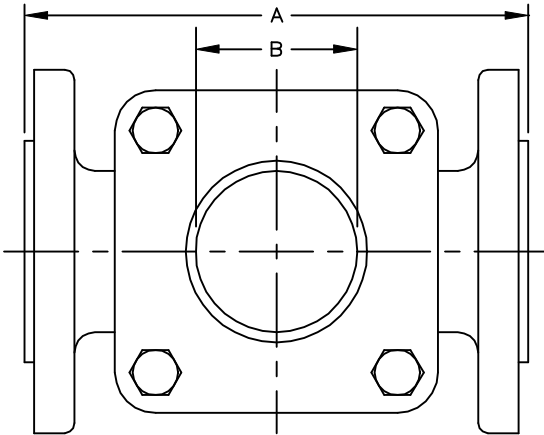

PLAIN
 STYLE F-910HPA (NF)-600

8
 INDICATOR OPTIONS

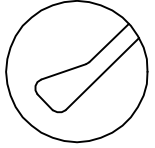

FLAPPER
 STYLE F-910HPA-600

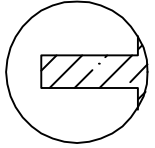

PTFE FLUTTER
 STYLE F-910HPA-FLTR-600

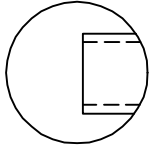

DRIP TUBE
 STYLE F-608HPA-600

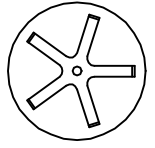

ROTOR
 STYLE F-960HPA-600



THIS DRAWING AND ALL INFORMATION ON IT IS THE PROPERTY OF JACOBY-TARBOX, DIVISION OF THE CLARK-RELiance CORPORATION. IT IS CONFIDENTIAL AND IS GIVEN TO YOU FOR A LIMITED PURPOSE AND MUST BE RETURNED UPON REQUEST. NEITHER THIS DRAWING NOR ANY PART OF IT NOR ANY INFORMATION CONCERNING IT MAY BE COPIED, EXHIBITED OR FURNISHED TO OTHERS NOR MAY PHOTOGRAPHS BE TAKEN OF ANY ARTICLE FABRICATED OR ASSEMBLED FROM THIS DRAWING WITHOUT CONSENT OF THE CLARK-RELiance CORPORATION.

PARTS LIST

PIECE NO.	NAME OF PART	QUAN.	MATERIAL	COMMENTS
1	BODY	1	SEE BELOW	
2	RETAINER	2	STEEL	
3	CUSHION	2	FIBER	
4	SEAL GASKET	2		
5	WINDOW	2	BOROSILICATE	
6	BOLT		STEEL	
7	NUT		STEEL	
8	INDICATOR			

OPTIONS
 DUAL UNIGLAS WINDOWS

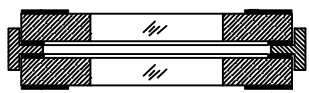

FULL VIEW DUAL WINDOWS



Factory Mutual System
 Approved

UNIGLAS WINDOW

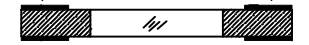

ASME CLASS P/T RATINGS

TEMP F	600 CLASS	
	STEEL	316 SS
-20 TO 100	1480	1440
150	1415	1340
200	1350	1240
250	1335	1180
300	1315	1120
350	1290	1075
400	1270	1030
450	1235	990
500	1200	955

STANDARD DESIGN MATERIALS:

BODY: ASTM A-216 WCB (CARBON STEEL)
 ASTM A-351 CF8M (316 SS)

RETAINER: ASTM A-516 GR. 70 (STEEL)
 FASTENERS: A354-BD/A194-2H (STEEL)
 INDICATOR: 316 SS FLAPPER & DRIP TUBE
 INDICATOR: PTFE ROTOR & FLUTTER

304/316 SS TRIM AVAILABLE

OPTIONAL ALLOYS FURNISHED UPON REQUEST

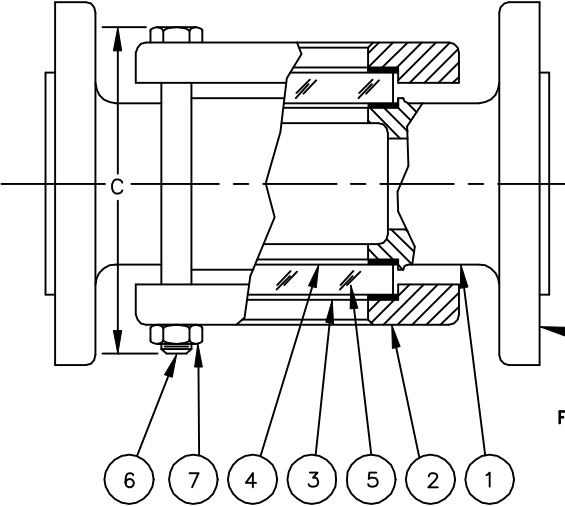

FLANGE CONNECTION PER
 ASME B16.5 CL600 RF

DIMENSIONS

PIPE SIZE	A		B		C		APPROX. WGT.		# BOLTS
	IN.	mm	IN.	mm	IN.	mm	LBS.	KGS.	
1/2&3/4	6-1/4	159	1	25	5-1/4	133	9-1/2	4.3	4
1	7-1/4	184	1-1/4	32	5-3/4	146	17	7.7	4
1-1/2	7-7/8	200	2	51	5-7/8	149	24	10.9	4
2	9	229	2	51	8-1/8	206	35	15.9	4
2-1/2&3	11-3/4	299	3-3/16	81	11-5/8	295	64	29	4
4	14-1/4	362	4-1/4	108	14-1/4	362	135	61.3	4
6	23-3/8	594	5-1/2	140	19-1/8	486	260	117.9	12
8	25-1/4	641	5-1/2	140	21-7/16	545	350	158.8	12