



Jerguson/Jacoby-Tarbox Eductors

Installation, Maintenance, and Operating Instructions

For use with cast and barstock metal eductors.
Models: SL, ML, HL, MLE, SG, HG, ULJ, and MLH

This manual has been prepared as a guide to those involved in the installation, use, and maintenance of Jerguson/Jacoby-Tarbox (JRG/JT) eductors. All instructions should be read and understood before beginning any installation, maintenance or operation of the JRG/JT eductors. Failure to follow this manual could result in the leakage of fluid, injury to personnel, or property damage.

Warning: Safety glasses should be worn when eductors are being installed or used in an area.

Introduction

Eductors work by accelerating the motive fluid that is passed through them. It is important that all downstream sections of the eductor be treated as an area of high velocity. JRG/JT metal eductors are designed to ANSI specifications. At no time should the eductor be subjected to pressures above the design pressure of the unit. To determine the maximum allowable pressure, the user should refer to a published dimension sheet or a certified drawing from JRG/JT.

Warning: Exceeding the design ratings of the eductor may cause property damage and/or physical injury to personnel. Exceeding the design ratings of the eductor will void all warranties on the eductor.

Applications

Eductor applications are sized using JRG/JT Technical Bulletins. You can request these from JRG/JT or your representative. For a specific application, a trained applications engineer will work with you.

Inspection

JRG/JT recommends that you inspect all eductors upon receipt. The model and material are stamped on the hex of the nozzle. The body size is stamped or cast into the side of the body on all units.

If the size, model, or material does not match your Purchase Order, contact JRG/JT or your representative before installing the unit.

Installation

Eductor installation should only be undertaken by experienced qualified personnel who have read and understand the instructions in this manual.

The user should refer to JRG/JT dimension sheets or drawings to obtain dimensional information and design ratings for a specific product.

Check the Figures 1,2, or 3 to determine the correct location for the suction and motive connection for your specific model of eductor. Different models of eductors will have the motive and suction attaching to different connections.

Eductors can be installed in any orientation and still perform properly. However, it is recommended that they be installed to drain automatically on shutdown.

All Piping used with JRG/JT eductors should be clean and free of foreign matter that could clog the eductor.

Pumping Liquid Suction's

- Eductors should be installed to minimize the back pressure caused by piping. This arrangement will allow the eductor to operate at maximum efficiency.
- It is recommended that eductors be used with gauge connections in the motive and suction connections. Also, a gauge port should be placed in the discharge line. This will make it easier to identify problems if they occur.
- Suction lines should be sized to meet or exceed the suction connection on the eductor. This will keep the friction losses in the suction line low.
- If back flow into the suction connection is a problem, a check valve should be installed in the suction line to prevent this. It is recommended that



the pressure drop caused by this valve be kept as low as possible. (Below 2 PSI if feasible.) Pressure drop caused by this check valve must be added to the friction losses in the suction connection of the eductor for sizing.

- In some applications, the eductor will not form a seal on the discharge unless the piping is designed to do this. Two suggestions for doing this follow: Addition of two standard 90° elbows close to the eductor can form this seal. Also, adding a very light check valve to the discharge line can form the seal.
- Eductors are not designed to be structural load bearing fittings. Do not impose system piping loads on eductors.

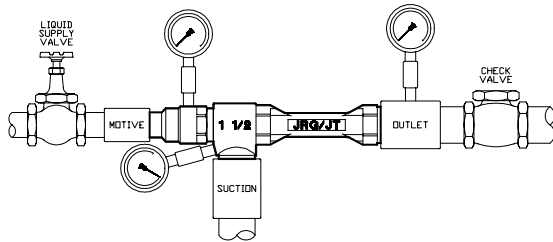

Figure 1: Pumping Liquids

Heating Liquids In-Line

- Refer to the Pumping Liquids section for Primary recommendations for installation.
- For faster removal of condensate from the steam line it is recommended that the steam connection be installed pointing up. If this is not possible or very fast heating is needed, a steam trap should be installed in the steam line.
- Steam must not contain over 20° F superheat or the unit will not perform as published in the Technical Bulletin.
- All steam lines should be properly insulated and sized to minimize friction loss.
- A check valve is recommended to help prevent water from being pushed into your steam lines.
- Some applications require that the discharge pressure be reduced for start up. An overflow line is recommended to do this. This line should be connected to a vessel to catch any overflow. It should also be placed in a protected area, as hot liquid may/will exit this line.

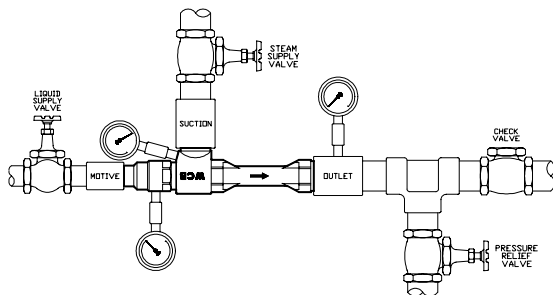

Figure 2: Heating Liquids

Pumping Gases

- When using liquid motives to pump gases the eductor should be placed with the discharge pointing 30° or more below horizontal to prevent liquid from splashing into the suction connection.
- Warning: When using steam as a motive fluid it is possible for an eductor to have frost on one end and be very HOT on the other end.

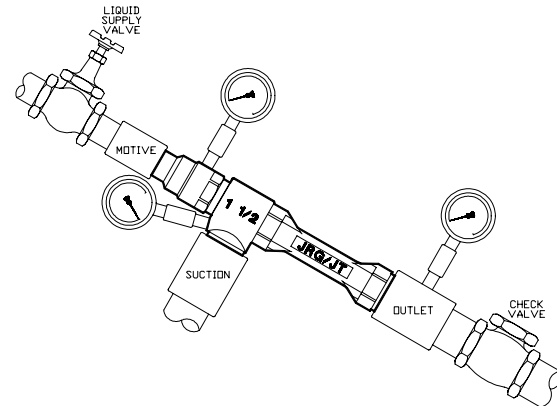

Figure 3: Pumping Gases

Installation Procedures

Before operation check the following things to assure correct operation.

1. Check to determine all installation procedures have been completed and all piping connections are tightened properly.
2. Check to be sure any restrictions in the discharge line have been removed.
3. Ensure that all valve in the discharge lines are open.
4. All valves in the suction line should be closed. All check valves should be examined to assure correct operation.

Operation Procedures

Pumping Liquids

1. Open the valve controlling the motive fluid quickly. Opening the valve slowly will not give the eductor the flow it needs to operate properly.
2. Open any valves in the suction line slowly.
3. If there are valves in the discharge line these may be closed slowly to increase the discharge pressure on the eductor.

Do not exceed the pressure that the eductor will work against as specified in the technical bulletin.

Heating Liquids



1. Open the valve controlling the motive fluid quickly. Opening the valve slowly will not give the eductor the flow it needs to operate properly.
2. Open the suction or steam valve slowly until desired discharge temperature is reached.
3. If a pressure relief valve is used in the discharge line, close it at this time. Then close the valve in the discharge to regulate the discharge pressure.

Pumping Gases

1. Open the valve controlling the motive fluid quickly. Opening the valve slowly will not give the eductor the flow it needs to operate properly.
2. Open any valves in the suction line slowly.
3. If there are valves in the discharge line, these may be closed slowly to increase the discharge pressure on the eductor.

Do not exceed the pressure that the eductor will work against as specified in the technical bulletin.

4. If the eductor is being used to prime a pump or siphon, close the suction valve when the suction liquid reaches the eductor; start the pump, and turn off the motive fluid to the eductor.

Maintenance

Warning: Before beginning any maintenance the eductor should be relieved of all pressure and/or vacuum. It should also be drained and purged of all fluids. Do not begin any maintenance until the eductor has reached ambient temperature.

Preventive

Things to check:

- Eductor nozzle for erosion or build up of debris.
- O-ring seals for wear or leakage.
- All connections for debris, corrosion, and tightness.
- Gage ports for debris or corrosion.
- Nozzle and bodies for wear.
- Steam traps and strainers for debris.

Preventive maintenance schedules are dependent on actual conditions in the user's facility. The user should create maintenance schedules based on their experience with the actual fluids being used in the eductor.

Troubleshooting

Pumping Liquids

Problem: *Suction flow is less than calculated.*

Possible causes:

- The suction piping has too much restriction. *Reduce the suction line restrictions.*
- The discharge pressure is higher than calculated. *Reduce discharge line restrictions.*

- The motive pressure is less than required. *Increase the motive pressure at the flowing condition.*
- The suction piping leaks. *All leaks in the suction piping must be sealed.*

Problem: *There is no suction flow.*

Possible causes:

- The temperature of the motive or suction fluid is higher than anticipated. *Lower the temperature of the fluid or reduce restrictions in the suction line.*
- The vapor pressure of the fluid is higher than calculated. *Reduce restrictions in the suction piping.*
- The motive nozzle is obstructed by debris. *Clean the nozzle of all restricting debris.*
- The suction connection is obstructed. *Clear the suction connection of all obstructions.*

Heating Liquids

Problem: *The eductor discharges live steam, causes piping vibration and creates loud noises, or has fluid exiting the suction connection.*

Possible causes:

- The discharge pressure was increased before the flow was established. *Start the operation over, being sure that the eductor has reached stable operation before increasing the discharge pressure.*
- The motive pressure is too low. *Increase the motive pressure.*
- The discharge pressure is too high. *Lower the discharge pressure. Install a pressure relief line for start up.*

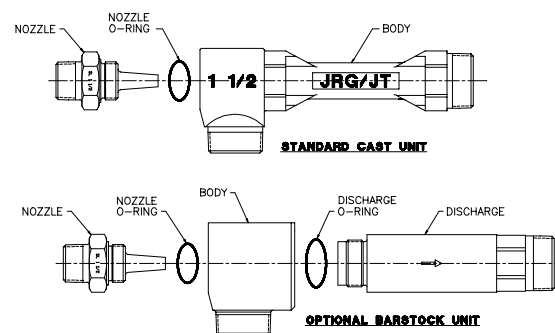

Figure 4: Components

For Sales & Service Contact:

Northeast Controls Incorporated ☐
 P.O. Box 275 - 123 Pleasant Avenue ☐
 Upper Saddle River, New Jersey 07458 USA ☐
 Tel: 201-327-7660 | Fax: 201-327-3242 ☐
 email: sales@northeastcontrolsinc.com ☐
 www.northeastcontrolsinc.com