



Model L8 FLOTECT® Liquid Level Switch

Specifications – Installation and Operating Instructions



Model L8



Model L8-WP

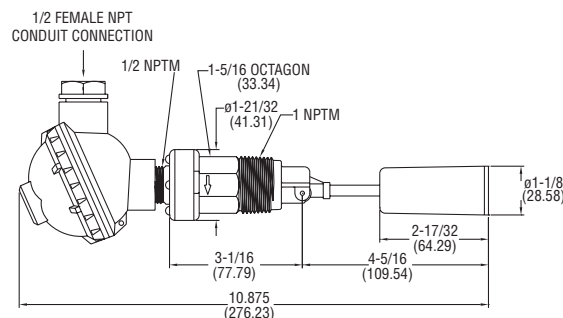
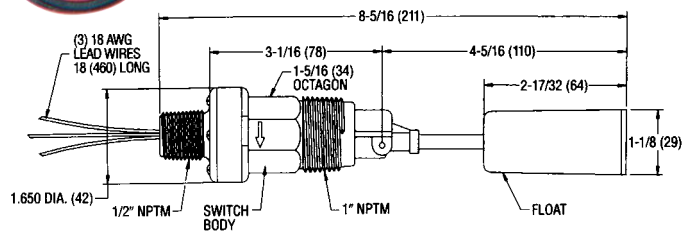

Model L8 Flotect® Liquid Level Switch features a leak proof body and float constructed from tough, durable polyphenylene sulfide (equivalent to Ryton®) which has excellent chemical resistance. Because the liquid level snap switch is magnetically actuated, there is no direct mechanical linkage to leak or fail, assuring longer life and decreased maintenance costs. This inexpensive unit is ideal for liquid level alarm, indication or control. Installation is quick and easy — simply install in a horizontal position with the index arrow pointing down.

The L8 Flotect® Liquid Level Control is UL recognized as an industrial motor controller per UL standard 508, suitable for mounting in a protected environment. This lightweight switch can be used in numerous chemical process, industrial systems and similar applications where process conditions are compatible with polyphenylene sulfide, ceramic 8 and 316 stainless steel. This liquid level switch provides accurate set-point control of liquids with specific gravities as low as 0.6. This compact and reliable control is designed to handle temperatures up to 212°F (100°C) and pressures to 150 psig (10 bar).

MODEL

L8 Level Switch

OPTIONS

-MV, Gold Plated Contacts, for dry circuits. Rated 1A @ 125 VAC; 1A resistive, 0.5A inductive @ 30 VDC. Example L8-MV

-INC, Inconel® Option. Inconel® replaces standard 316 SS wetted parts. Wetted parts are Inconel®, ceramic 8, and Polyphenylene Sulfide. Example: L8-INC

-WP, Weatherproof Enclosure. Optional housing is phenylp-
loxide and provides weatherproof protection for electrical wiring. Example: L8-WP

SPECIFICATIONS

Service: Compatible liquids.

Wetted Materials:

Float and Body: Polyphenylene Sulfide (PPS).

Pin and Spring: 316 SS or Inconel®.

Magnet: Ceramic 8.

Temperature Limit: 212°F (100°C).

Pressure Limit: 150 psig (10.34 bar).

Enclosure Rating: General purpose. WP option is weatherproof.

Switch Type: SPDT snap switch. MV option is a SPDT gold contact snap switch.

Electrical Rating: 5A @ 125/250 VAC, 5A resistive, 3A inductive @ 30 VDC. MV option: 1A @ 125 VAC, 1A resistive, 0.5A inductive @ 30 VDC.

Electrical Connections: 18 AWG, 18" (460 mm) long.

Conduit Connection: 1/2" male NPT.

Process Connection: 1" male NPT.

Mounting Orientation: Horizontal with index arrow pointing down.

Weight: 5 oz (0.142 kg).

Agency Approvals: CE, UL 508 for US and Canada.

Specific Gravity: 0.6 minimum.

Northeast Controls Incorporated □

Upper Saddle River, New Jersey 07458 USA □

Tel: 201-327-7660 | Fax: 201-327-3242 | sales@nciweb.com

INSTALLATION

1. The Model L8 Level Switch is designed for use in clean, compatible process media free from scale, debris and other foreign material which could collect on the float and impede its movement. Build up from such materials will prevent proper operation. See wetted materials list in the specifications to assure compatibility with process liquids.
2. Unpack switch and remove any packing material from the switch and float. Due to variations in fittings and amount of thread engagement, float must be checked for proper operation during installation.
3. Use Teflon® thread tape or other suitable pipe joint compound to seal the 1" NPT mounting connection. Avoid excess sealant which could interfere with float movement. Do not exceed 50 ft/lb (40n/m) torque on the switch housing. Damage can result.
4. Install switch in a horizontal position with index arrow pointing down.
5. Wire in accordance with local electrical codes. Lead wire color codes are as follows. Black - Common, Red - Normally Closed, Blue - Normally Open. Normal is the contact condition when liquid level is below the actuation point. Closed contacts open and open contacts close when liquid level lifts the float to the actuation point.
6. Switch electrical components must be protected from moisture at all times. If necessary, install a lightweight, waterproof junction box over the 1/2" NPT threaded stem. Do not place mechanical loading on the switch housing. Permanent damage can occur. Use flexible Romex sheathing or equivalent.

MAINTENANCE

The Model L8 Liquid Level Switch is not field serviceable and should be returned if repair is needed (field repair should not be attempted and may void warranty). Be sure to include a brief description of the problem plus any relevant application notes. Contact customer service to receive a return goods authorization number before shipping.

Teflon® is a registered trademark of E.I. du Pont de Nemours and Company.
Inconel® is a registered trademark of Huntington Alloys Corporation.
Ryton® is a registered trademark of Chevron Phillips Chemical Company.