

BILL OF MATERIAL

ITEM	PART NO.	QUAN.	DESCRIPTION	MATERIAL	DWG. NO.
1	PI*-14	1	ILLUMINATOR HOUSING	SNT.STL.	C-9138
2	PI-2	1	COVER, REMOVABLE	STN. STL	B-9137
3	PI*-8	1	GLASS STRIP, GREEN (TEMPER)	GLASS	B-9137
4	PI*-7	1	GLASS STRIP, RED	GLASS	B-9137
5	E11-7	4	WING SCREW, 10-24x1/2	STEEL	
6	PI-29	+	REFLECTOR LAMP		
7	GI40-23	+	LAMP SOCKET, LEVITON 9883	PORCELAIN	
8	PI-13	+	SPACER	STEATITE	PS-7014-A
9	X172941	+	SCREW, RH MACH. 10-24x1/2	STN. STL.	
10	X172967	+	SCREW, RH MACH. 10-24x1 1/4	STN. STL.	
11	X172991	+	NUT, ACORN 10-24	STN. STL.	
12	GI40-8	1	COMPOSITION BUSHING & NUT 3/8		
13	PI-20	1	NAME PLATE	ALUMINUM	SK 1-25-62
14	X173200	2	SHEET METAL SCREW	STEEL	
15	X172976	1	GREEN GROUND SCREW 10-32x3/8	S.S	

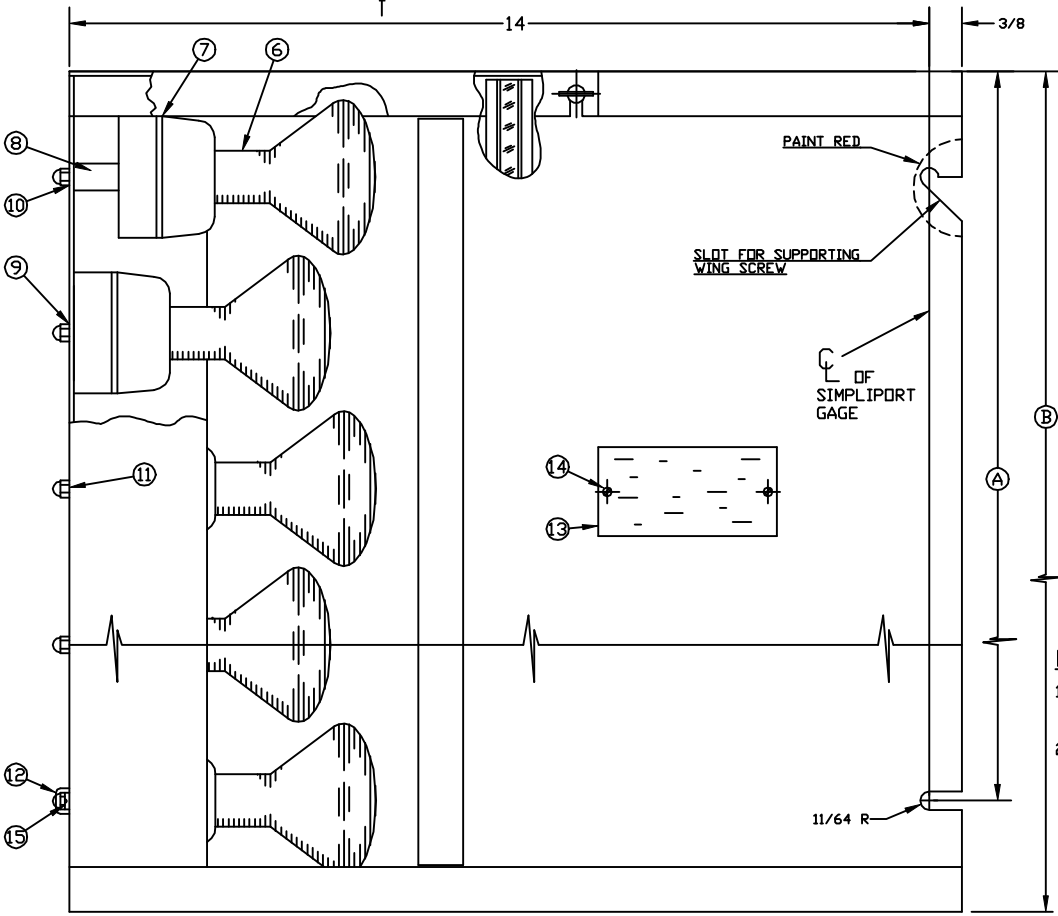

NOTE:

- * TO COMPLETE PART NO. ADD NUMBER OF WINDOW UNITS ON SIMPLIPORT FOR WHICH ILLUMINATOR IS REQUIRED.
- + FOR QUANTITIES SEE PART LIST.

DIMENSION CHART

ILLUMINATOR PART NO.	A	B
PI 5R	9 1/2	12 1/2
PI 6R	11 7/8	14 7/8
PI 7R	14 1/4	17 1/4
PI 8R	16 5/8	19 5/8
PI 9R	19	22
PI 10R	21 3/8	24 3/8
PI 11R	23 3/4	26 3/4

SIMPLIPORT GAGE ASS'Y PER DWG. NO. B-9130

REV	DESCRIPTION	DATE	SIG

UNLESS OTHERWISE NOTED
 TOLERANCES (1)
 DECIMAL & STOCK C.0020
 FIN. FRACTIONAL (UP TO 1", NOT INCL.) C.0100
 FIN. FRACTIONAL (1" INCL., UP TO 3") 1/64
 FIN. FRACTIONAL (3" INCL., UP TO 6") 1/32
 FIN. FRACTIONAL (6" INCL., UP TO 12") 1/16
 FIN. FRACTIONAL (12" & OVER) 1/8
 ANGLES 17
 MACHINE FINISH-125 OR SMOOTHER
 REMOVE BURRS AND SHARP EDGES

THE CLARK-RELIANCE CORP.
 STRONGSVILLE, OHIO

ILLUMINATOR ASSEMBLY
 FOR SIMPLIPORT GAGE

MATERIAL	
DRAWN B. CLINE	SCALE NONE
CHKD.	DATE 6-19-92
DRAWING NO.	REV.
B-9131	7